

City Council

200 North Brazil

Regular Meeting

Los Fresnos, TX 78566

<http://citylf.cloudaccess.net/en/>

~ Agenda ~

Tuesday, December 11, 2018

6:00 PM

City Hall

NOTICE IS HEREBY GIVEN THAT THE CITY COUNCIL OF THE CITY OF LOS FRESNOS PURSUANT TO CHAPTER 551, TITLE 5 OF THE TEXAS GOVERNMENT CODE, THE TEXAS OPEN MEETINGS ACT, WILL MEET ON TUESDAY, DECEMBER 11, 2018 AT 6:00 PM AT CITY HALL, 200 NORTH BRAZIL ST, LOS FRESNOS, TX 78566.

I. AGENDA

1. Call meeting to order
2. Invocation and Pledge of Allegiance
3. Consent Agenda
 1. Consideration and ACTION to approve the Minutes from November 13th & 15th, 2018.
 2. Consideration and ACTION to approve the renewal of a Memorandum of Understanding between the Los Fresnos Police Department and the Los Fresnos Consolidated Independent School District Police Department.
 3. Consideration and ACTION to acknowledge the City Manager's decision to utilize \$6,500 from the contingency fund for final stabilization.
 4. Consideration and ACTION to approve Los Fresnos Poilce Department Policies.
4. Visitors remarks-To speak you must sign in with the City Secretary prior to the meeting you have a limit of 3 minutes to speak.
5. Action Items

1. Discuss, consider, and adopt resolution designating an engineering service provider to complete application and project related engineering services for the Texas Department of Agriculture's 2019-2020 TxCDBG Community Development fund.
 2. Consideration and ACTION to award bid for TxCDBG State Contract 7217269 contingent on TDA approval of Amendment #1.
 3. Consideration and ACTION to approve or reject an Inter local Agreement with Bayview Irrigation District.
 4. Consideration and ACTION to approve designating December 31st as a holiday.
 5. Consideration and ACTION for the Mayor to support and participate in the HEB 2019 Step Up Community Challenge.
 6. Consideration and ACTION for the City Council members to support and participate in the HEB 2019 Step Up Community Challenge.
6. Acknowledgement of City Manager's Report
1. City Manager Report A. Wastewater Plant Update B. Water Plant Update C. Water & Wastewater Engineering Study D. Whipple Road Wastewater Extension E. Nature Park F. Hike & Bike Trails G. CDBG 2017-2018 Grant H. Henderson Road Project I. City Hall Project J. Building Inspections K. Underground Canal L. Dog Park M. Development and Annexation Plans N. Update Planning & Zoning Ordinance O. Economic Development
7. Acknowledgement of Department Head Reports
1. Financial Report 1. Monthly 2. Year to Date 3. Sales Tax
 2. Public Works Report 1. Water and Wastewater Activity 2. Calls for Service 3. Building Permits 4. Recycling
 3. Police Department 1. Arrests 2. Incidents 3. Accidents
 4. Municipal Court 1. Monthly Report
 5. Library Report 1. Monthly Report
 6. Fire Marshal's Report 1. Monthly Report
8. Adjournment

This is to certify that I, Jacqueline Moya, posted this agenda on the front bulletin board of the City Hall on December 6, 2018 on or before 5:30 p.m. and it shall remain so posted continuously for at least 72 hours preceding the scheduled time of said meeting.

Jacqueline Moya, City Secretary

Persons with any disabilities that would like to attend meetings must notify City Secretary 24 hours in advance so that the City can make arrangements for that disabled person.

City Council
200 North Brazil
Los Fresnos, TX 78566

Meeting: 12/11/18 06:00 PM
Department: City Secretary
Category: Minutes
Prepared By: Jacqueline Moya
Initiator: Jacqueline Moya
Sponsors:
DOC ID: 2853 A

SCHEDULED

ACTION ITEM (ID # 2853)

**Consideration and ACTION to approve the Minutes from
November 13th & 15th, 2018.**

I recommend approval.

City Council

200 North Brazil

Los Fresnos, TX 78566

<http://citylf.cloudaccess.net/en/>

Regular Meeting

~ Minutes ~

Tuesday, November 13, 2018

6:00 PM

City Hall

Agenda

1. Call meeting to order
Mayor Narvaez called the meeting to order at 6:00 p.m.
2. Invocation and Pledge of Allegiance
Mr. Milum gave the invocation and led the audience in the pledge of allegiance.

Presentation

Presentation of Certificate of Achievement for Excellence Financial Reporting.

Mayor Narvaez thanked and congratulated the city employees, administrators, and city council for their excellent job in contributing to get the Certificate of Achievement for Excellence Financial Reporting award.

RESULT: NO ACTION

Presentation by the City IT Technician of upcoming projects.

Dale House, the City's IT explained to the council the number of cameras that are currently placed in various locations both in house and out. Mr. House let the council know that the recordings last 7 days. The Police Department has been able to use this footage to investigate illegal dumping and other activities in the parks and on Highway 100.

Mr. House answered questions for the council and discussed the plans for the installation of new cameras.

RESULT: NO ACTION

Consent Agenda

Consideration and ACTION to approve the Minutes fro October 9, 2018 & October 23, 2018.

Motion was made and seconded to approve the minutes from October 9, 2018 & October 23, 2018.

RESULT:	ADOPTED [UNANIMOUS]
MOVER:	Swain Real, Councilman
SECONDER:	Javier Mendez, Councilman
AYES:	Garza, Narvaez, Cruz, Real, Mendez
ABSENT:	Juan Munoz

Consideration and ACTION to approve the Investment Portfolio Summary Report ended as of September 30, 2018.

Attachment: CC MIN 11 13 18 (2853 : Minutes)

Motion was made and seconded to approve the Investment Portfolio Summary Report ended as of September 30, 2018.

RESULT:	ADOPTED [UNANIMOUS]
MOVER:	Swain Real, Councilman
SECONDER:	Javier Mendez, Councilman
AYES:	Garza, Narvaez, Cruz, Real, Mendez
ABSENT:	Juan Munoz

Consideration and ACTION to approve the second reading of Ordinance 496 authorizing and allowing, under the act governing the Texas Municipal Retirement System, "updated service credits" in said system on an annual basis for service performed by qualifying members of such system who at the effective date of the allowance are members of the City of Los Fresnos; providing for increased prior and current service annuities for retirees and beneficiaries of deceased retirees of the city; and establishing an effective date for the ordinance.

Motion was made and seconded to approve the second reading of Ordinance 496 authorizing and allowing, under the act governing the Texas Municipal Retirement System, "updated service credits" in said system on an annual basis for service performed by qualifying members of such system who at the effective date of the allowance are members of the City of Los Fresnos; providing for increased prior and current service annuities for retirees and beneficiaries of deceased retirees of the city; and establishing an effective date for the ordinance.

RESULT:	ADOPTED [UNANIMOUS]
MOVER:	Swain Real, Councilman
SECONDER:	Javier Mendez, Councilman
AYES:	Garza, Narvaez, Cruz, Real, Mendez
ABSENT:	Juan Munoz

Consideration and ACTION to approve the second reading of Ordinance 497 establishing fees and regulations for a Dockless Vehicle permit program.

Motion was made and seconded to approve the second reading of Ordinance 497 establishing fees and regulations for Dockless Vehicle permit program.

RESULT:	ADOPTED [UNANIMOUS]
MOVER:	Swain Real, Councilman
SECONDER:	Javier Mendez, Councilman
AYES:	Garza, Narvaez, Cruz, Real, Mendez
ABSENT:	Juan Munoz

Consideration and ACTION to approve resolution to amend TxCDBG State Contract 7217269 to include street improvements to East 6th Street into project per revised engineering design.

Motion was made and seconded to approve resolution to amend TxCDBG State Contract 7217269 to include street improvements to East 6th Street into project per revised engineering design.

RESULT:	ADOPTED [UNANIMOUS]
MOVER:	Swain Real, Councilman
SECONDER:	Javier Mendez, Councilman
AYES:	Garza, Narvaez, Cruz, Real, Mendez
ABSENT:	Juan Munoz

Consideration and ACTION to purchase Christmas Decorations.

Motion was made and seconded to approve the purchase of Christmas Decorations.

RESULT:	ADOPTED [UNANIMOUS]
MOVER:	Swain Real, Councilman
SECONDER:	Javier Mendez, Councilman
AYES:	Garza, Narvaez, Cruz, Real, Mendez
ABSENT:	Juan Munoz

Visitors remarks-To speak you must sign in with the City Secretary prior to the meeting you have a limit of 3 minutes to speak.

There no comments from the public.

Mayor Narvaez took the opportunity to thank Bibi Garza and Javier Mendez for their service on the City Council and presented them with plaques.

Mr. Mendez thanked the staff and council.

Action Items

Consideration and ACTION on approval of a service agreement with the Cameron County Fair and Livestock Show.

Valerie Arizmendi with the Cameron County Fair & Livestock Show stated she was there to ask the council if they would support them once again. She stated that the program continues to grow and explained how the scholarship program works. She thanked the council for their support.

Mr. Milum and the council discussed the sponsorship.

Motion was made and seconded to approve a service agreement with the Cameron County Fair and Livestock Show in the amount of \$5,500.

RESULT: ADOPTED [UNANIMOUS]
MOVER: Polo Narvaez, Mayor
SECONDER: Swain Real, Councilman
AYES: Garza, Narvaez, Cruz, Real, Mendez
ABSENT: Juan Munoz

Consideration and ACTION to approve a service agreement with Los Fresnos Rodeo Committee.

Mike Todd with the Los Fresnos Rodeo Committee handed out a few documents about the Rodeo to the council. They included the flyer for last years Rodeo and the sponsorship packages available. Mr. Todd gave an update on the upcoming cook-off which the City is also a sponsor. Mr. Todd informed the Council of the plans scheduled for the upcoming rodeo and plans to make improvements to the rodeo grounds. He also explained to the how the scholarship money is awarded to the students.

Motion was made and seconded to approve a service agreement with the Los Fresnos Rodeo Committee in the amount of \$13,500.

RESULT: ADOPTED [UNANIMOUS]
MOVER: Swain Real, Councilman
SECONDER: Bibi Garza, Councilwoman
AYES: Garza, Narvaez, Cruz, Real, Mendez
ABSENT: Juan Munoz

Consideration and ACTION to consider approving a request for fill dirt from the property owner at 30788 State HWY 100 to raise the elevation of the site.

Mr. Milum explained that the request was from the owner of the property that CHS operates which took over the International Educational Services located at 30788 State Hwy 100. The owner will be building several additions to their facility and is in need of fill dirt to raise the elevation. Mr. Milum stated the city has dirt along the drainage dirt left over from the development behind the new city hall property.

Motion was made and seconded to approve a request for fill dirt from the property owner at 30788 State Hwy 100 to raise the elevation of the site.

RESULT: ADOPTED [UNANIMOUS]
MOVER: Swain Real, Councilman
SECONDER: Yolanda H. Cruz, Councilwoman
AYES: Garza, Narvaez, Cruz, Real, Mendez
ABSENT: Juan Munoz

Consideration and ACTION to consider approving a request to discount the cost of building permits for a expansion at 30788 State HWY 100 for Comprehensive Health Services.

Mr. Milum explained that this location was the same as the one discussed in the previous action item. Mr. Milum stated that the expansion would be extensive and would require a lot of permits. The owner of the property is requesting a discount on the permits. Mr. Milum did not make a recommendation in the board agenda note because he feels its

something very unusual and all ramifications in giving the discount needs to be considered.

Mr. Milum and the council discussed the possible options in allowing a discount for the permits. Job retention that is happening will increase with these additions as well as the owner allowing the City Sign on the property are key factors.

Motion was made and seconded to approve a 15% discount on the cost of building permits for a expansion at 30788 State Hwy 100 for Comprehensive Health Services.

RESULT:	ADOPTED [UNANIMOUS]
MOVER:	Swain Real, Councilman
SECONDER:	Polo Narvaez, Mayor
AYES:	Garza, Narvaez, Cruz, Real, Mendez
ABSENT:	Juan Munoz

Consideration and ACTION to approve Change Order #1for the new City Hall project.

Mr. Milum explained that after the ground breaking ceremony he mentioned there was an area of the ground that was not compacting as it should. As they dug about 5 feet deep the soil was very liquidy. Additional soil samples were collected to determine what could be done get the compaction that is needed. The solution will be to dig an additional 8-12 inches deep and add fly ash. This material will dry out the soil and harden. This process would cost \$28,557. The money will be taken from the contingency fund which has a balance of \$100,000.

Mr. Milum answered questions for the council.

Motion was made and seconded to approve Change Order #1 for the new City Hall project.

RESULT:	ADOPTED [UNANIMOUS]
MOVER:	Polo Narvaez, Mayor
SECONDER:	Swain Real, Councilman
AYES:	Garza, Narvaez, Cruz, Real, Mendez
ABSENT:	Juan Munoz

Consideration and ACTION to approve a budget amendment for the Police Department.

Mr. Milum explained that the budget amendment was for the vest grant that is given through the federal government. This grant provides vest for the police. An estimated \$2,500 was budgeted but we will receive the amount of the grant awarded for \$3,165.60. This budget amendment would reflect that.

Motion was made and seconded to approve a budget amendment for the Police Department.

RESULT: ADOPTED [UNANIMOUS]
MOVER: Bibi Garza, Councilwoman
SECONDER: Javier Mendez, Councilman
AYES: Garza, Narvaez, Cruz, Real, Mendez
ABSENT: Juan Munoz

Consideration and ACTION to approve budget amendment for the Community Health Program.

Mr. Milum explained that \$45,000 was budgeted for the program but we were awarded \$60,000. This budget amendment would reflect that. Mr. Milum explained the program to council and how well it was doing.

Mr. Milum answered questions for the board.

Motion was made and seconded to approve a budget amendment for the Community Health Program.

RESULT: ADOPTED [UNANIMOUS]
MOVER: Javier Mendez, Councilman
SECONDER: Yolanda H. Cruz, Councilwoman
AYES: Garza, Narvaez, Cruz, Real, Mendez
ABSENT: Juan Munoz

Consideration and ACTION to nominate a person for the 2019 RGV Walk of Fame.

Council member Javier Mendez stated that last year he recommended Simon Vega but Pam Denny was selected instead. Mr. Mendez would like to nominate Simon Vega if the council would support him.

Motion was made and seconded to nominate Simon Vega for the 2019 RGV Walk of Fame.

RESULT: ADOPTED [UNANIMOUS]
MOVER: Javier Mendez, Councilman
SECONDER: Bibi Garza, Councilwoman
AYES: Garza, Narvaez, Cruz, Real, Mendez
ABSENT: Juan Munoz

Discussion, consideration and ACTION on Legislative Priorities.

Mr. Milum explained that there will be a joint meeting on December 1, 2018 Small cities coalition and the Large cities coalition to determine a voice from the valley. Mr. Milum explained what the benefits would be if both coalitions joined together.

Mr. Milum answered questions for the council and discussed other options.

Motion was made and seconded to allow Mark Milum to make the recommendation based on the Small & Large Cities Coalition meeting but to include concerns over windstorm insurance increasing, leave local control to cities, not restricting annexation, not reducing the revenue cap, leave funding for parks alone, need funding for our Nature Park & Boys & Girls Club expansion and stream lining the environmental process with Texas Parks & Wildlife.

RESULT: ADOPTED [UNANIMOUS]
MOVER: Polo Narvaez, Mayor
SECONDER: Javier Mendez, Councilman
AYES: Garza, Narvaez, Cruz, Real, Mendez
ABSENT: Juan Munoz

Acknowledgement of City Manager's Report

City Manager Report A. Wastewater Plant Update B. Water Plant Update C. Water & Wastewater Engineering Study D. Whipple Road Wastewater Extension E. Nature Park F. Hike & Bike Trails G. CDBG 2017-2018 Grant H. Henderson Road Project I. City Hall Project J. Building Inspections K. Underground Canal L. Dog Park M. Development and Annexation Plans N. Update Planning & Zoning Ordinance O. Economic Development

Mr. Milum explained that the construction for the Wastewater Plant is ongoing. The city will try to get funding for the Water Plant upgrades through the Texas Water Development Board. Mr. Milum stated that the city has the engineering funds for the Whipple Road Wastewater extension but were pending a agreement between TXDOT with the City through the Regional Metropolitan Authority that is doing the engineering for the project. Mr. Milum gave an update on the CDBG 2017/2018 Grant stating that the resolution passed would allow adding 6th Street to the drainage improvements.

Mr. Milum answered questions for the council.

Motion was made and seconded to acknowledge the City Manager's Report.

RESULT: ADOPTED [UNANIMOUS]
MOVER: Polo Narvaez, Mayor
SECONDER: Yolanda H. Cruz, Councilwoman
AYES: Garza, Narvaez, Cruz, Real, Mendez
ABSENT: Juan Munoz

Acknowledgement of Department Head Reports

Financial Report 1. Monthly 2. Year to Date 3. Sales Tax

Motion was made and seconded to approve the Financial report

RESULT: ADOPTED [UNANIMOUS]
MOVER: Polo Narvaez, Mayor
SECONDER: Javier Mendez, Councilman
AYES: Garza, Narvaez, Cruz, Real, Mendez
ABSENT: Juan Munoz

Public Works Report 1. Water and Wastewater Activity 2. Calls for Service 3. Building Permits 4. Recycling

Motion was made and seconded to approve the Public Works Report.

RESULT: ADOPTED [UNANIMOUS]
MOVER: Polo Narvaez, Mayor
SECONDER: Javier Mendez, Councilman
AYES: Garza, Narvaez, Cruz, Real, Mendez
ABSENT: Juan Munoz

Police Department 1. Arrests 2. Incidents 3. Accidents

Motion was made and seconded to approve the Police Department Report.

RESULT: ADOPTED [UNANIMOUS]
MOVER: Polo Narvaez, Mayor
SECONDER: Javier Mendez, Councilman
AYES: Garza, Narvaez, Cruz, Real, Mendez
ABSENT: Juan Munoz

Municipal Court 1. Monthly Report

Motion was made and seconded to approve the Municipal Court Report.

RESULT: ADOPTED [UNANIMOUS]
MOVER: Polo Narvaez, Mayor
SECONDER: Javier Mendez, Councilman
AYES: Garza, Narvaez, Cruz, Real, Mendez
ABSENT: Juan Munoz

Library Report 1. Monthly Report

Motion was made and seconded to approve the Library Report.

RESULT: ADOPTED [UNANIMOUS]
MOVER: Polo Narvaez, Mayor
SECONDER: Javier Mendez, Councilman
AYES: Garza, Narvaez, Cruz, Real, Mendez
ABSENT: Juan Munoz

Fire Marshal's Report 1. Monthly Report

Motion was made and seconded to approve the Fire Marshal's Report.

RESULT: ADOPTED [UNANIMOUS]
MOVER: Polo Narvaez, Mayor
SECONDER: Javier Mendez, Councilman
AYES: Garza, Narvaez, Cruz, Real, Mendez
ABSENT: Juan Munoz

9. Adjournment

The meeting was closed at 7:35 p.m.

Presiding Officer of the Council

Recorder

Attachment: CC MIN 11 13 18 (2853 : Minutes)

City Council

200 North Brazil

Los Fresnos, TX 78566

<http://citylf.cloudaccess.net/en/>

Special Meeting

~ Minutes ~

Thursday, November 15, 2018

6:00 PM

Community Center

Call to Order

The meeting was called to order at 6:00 PM by Mayor Polo Narvaez

Invocation and Pledge of Allegiance

Election Returns

Canvass of Election Returns

Mayor Narvaez read the canvass report as follows:

Place 3

For James Herrera:	Precinct 3	324 votes
	Precinct 65	87 votes
	Precinct 66	307 votes
	Total	718 votes

For Javier Mendez	Precinct 3	355 votes
	Precinct 65	109 votes
	Precinct 66	241 votes
	Total	705 votes

Place 4

For Joe Collinworth	Precinct 3	541 votes
	Precinct 65	160 votes
	Precinct 66	464 votes
	Total	1165 votes

RESULT: NO ACTION

Consideration and ACTION to approve a Resolution Declaring Results of Election.

Motion was made and seconded to approve a Resolution Declaring Results of Election.

RESULT:	ADOPTED [UNANIMOUS]
MOVER:	Swain Real, Councilman
SECONDER:	Polo Narvaez, Mayor
AYES:	Bibi Garza, Polo Narvaez, Yolanda H. Cruz, Swain Real
ABSENT:	Juan Munoz, Javier Mendez

Oath of Office

Attachment: CC MIN 11 15 18 (2853 : Minutes)

Mrs. Jacqueline Moya, City Secretary gave the Oath of Office to James Herrera as elected Member of Council Place 3 and Joe Collinsworth as elected Member of Council Place 4.

Mr. Collinsworth thanked everyone who went out and voted regardless of who they voted for.

Mr. Herrera thanked everyone who came and voted as well. They hope to continue the great work the current council has done.

RESULT: NO ACTION

Visitors Remarks-To speak you must sign in with City Secretary prior to the meeting and you have a limit of 3 minutes to speak.

There were no comments.

Adjournment

The meeting was closed at 6:09 PM

Presiding Officer of the Council

Recorder

City Council
200 North Brazil
Los Fresnos, TX 78566

Meeting: 12/11/18 06:00 PM
Department: City Secretary
Category: Agreement
Prepared By: Jacqueline Moya
Initiator: Jacqueline Moya
Sponsors:
DOC ID: 2852 B

SCHEDULED

ACTION ITEM (ID # 2852)

Consideration and ACTION to approve the renewal of a Memorandum of Understanding between the Los Fresnos Police Department and the Los Fresnos Consolidated Independent School District Police Department.

This is the annual agreement with have with LFCISD for police department support. The financial amounts are on page 1 for a total of \$19,380.00. The rest of the agreement is exactly as it always has been. LFCISD is truly a great partner with both parties providing each other tremendous support as needed.

I recommend approval.

MEMORANDUM OF UNDERSTANDING BETWEEN THE LOS FRESNOS C.I.S.D. POLICE DEPARTMENT AND THE LOS FRESNOS POLICE DEPARTMENT

THE STATE OF TEXAS

KNOW ALL MEN BY THESE PRESENTS

COUNTY OF CAMERON

I. PARTIES

THIS AGREEMENT, is entered into by and between the LOS FRESNOS C.I.S.D. POLICE DEPARTMENT of the State of Texas, and hereinafter referred to as the District Police and the LOS FRESNOS POLICE DEPARTMENT, a city in the County of Cameron, Texas referred to hereinafter as the City Police Department. This agreement and service is entered into under the Interlocal Agreement Act. Any party paying for the performance of any function or service shall make these payments from current revenues available to the paying party.

II. PURPOSE

The purpose of this agreement is to establish an understanding and cooperation between the District Police and the City Police Department.

The Los Fresnos Consolidated Independent School District (Los Fresnos C.I.S.D.) has established and communicated a policy clearly establishing the parameters of the District Police. The Los Fresnos C.I.S.D. also understands the need to work with law enforcement agencies having overlapping jurisdiction with the Los Fresnos C.I.S.D. Additionally, the City Police Department is equally dedicated to serving the public by coordinating and communicating with the District Police.

III. AGREEMENT

The City Police Department and the District Police agree to aid each other as may be requested and as each is capable. It is understood that the City Police Department has jurisdiction throughout the City of Los Fresnos and that the District Police have jurisdiction throughout the school district. It is also understood and agreed that the primary responsibility of the District Police will include law enforcement activities within school campus boundaries of the Los Fresnos C.I.S.D. during normal school hours and at other times as may be necessary. The District Police will coordinate after school hours law enforcement activities with the City Police Department.

In anticipation of the need for the following services; use of the city jail facilities, prisoner transport to the Cameron County Jail (\$2,500), Dispatching Services, TCIC/NCIC, and Call Logging (\$7,000), communication services radio trunking usage - [15 radios @ \$10 monthly] \$1,980, and four (5) City Police Officers at the home football games for six (6) hours (5:45pm - 11:45pm) \$5,400, Additionally, [in anticipation of the need for the use of the training facilities](#), and [the gun range the Los Fresnos C.I.S.D. Police Department agrees to pay the City of Los Fresnos Police Department the amount of two thousand five hundred and no/100ths dollars \(\\$2,500\) annually](#) for the use of these facilities. The total that will be paid to the City of Los Fresnos annually is Nineteenth thousand, three hundred and eighty and no/100ths dollars (\$19,380.00). These funds will be paid in March of 2019.

IV.
TERM

The term of this agreement shall be for a twelve (12) month period from the date of this agreement. However, either party upon thirty (30) days written notice may terminate without cause this agreement.

V.
INSURANCE AND INDEMNIFICATION

5.1 **Governmental Functions.** Notwithstanding any provision to the contrary herein, this agreement is a contract for and with respect to the performance of governmental functions by governmental entities. The relationship of the City and the District shall be that of independent contractors.

5.2 **City Insurance and Indemnification.** The Los Fresnos C.I.S.D. shall have no liability whatsoever for the actions of, or failure to act by, any officers, employees, subcontractors, agents or assigns of the City, or for or with respect to this Agreement, and the City covenants and agrees that:

5.2.1 The City shall be solely responsible for and with respect to any claim or cause of action arising out of or with respect to any act, omission or failure to act by the City or its agents, officers, employees and subcontractors, while performing any function or providing or delivering any service undertaken by the City pursuant to this Agreement;

5.2.2 The City shall be solely responsible for procuring and maintaining in effect any insurance coverage it may, in its sole discretion, deem necessary or appropriate to protect its interests.

5.3 **District Insurance and Indemnification.** The city shall have no liability whatsoever for the actions of, or failure to act by, any officers, employees, subcontractors, agents or assigns of the Los Fresnos C.I.S.D., or for or with respect to the this Agreement by the District, and the District covenants and agrees that:

5.3.1 The Los Fresnos C.I.S.D. shall be solely responsible for and with respect to any claim or cause of action arising out of or with respect to any act, omission or failure to act by the Los Fresnos C.I.S.D. or its agents, officers, employees and subcontractors, while performing any function or undertaking any use of the Land and this Agreement;

5.3.2 The Los Fresnos C.I.S.D. shall be solely responsible for procuring and maintaining in effect any insurance coverage it may, in its sole discretion, deem necessary or appropriate to protect its interests.

5.4 **Governmental Immunity.** Nothing in this Agreement shall be deemed to waive, modify or amend any legal defense available at law or in equity to either the City or Los Fresnos C.I.S.D. nor to create any legal rights or claim on behalf of any third party. Neither the Los Fresnos C.I.S.D. nor the City waives, modifies, or alters to any extent whatsoever the availability of the defense of governmental immunity under the laws of the State of Texas. No provision of this agreement is a consent to suit.

VI.
MISCELLANEOUS

6.1 This agreement contains the complete expression of the agreement between the parties hereto, and there are not promises, representations, agreements, warranties, or inducements except such as are made herein and fully set forth. Any party paying for the performance of any function, services, or improvements to the demised premises shall make these payments from current revenues available to the paying party. No alterations of any of its terms, covenants or conditions shall be binding unless reduced to writing and signed by the parties hereto. It is agreed that all of the rights, remedies, and benefits provided by this agreement shall be cumulative, and shall not be exclusive of any other rights, remedies and benefits allowed by law.

6.2 Nothing herein may be construed as the formation of a partnership, joint venture, or other business organization or any description between the parties.

6.3 In the event one or more of the provisions of this agreement shall for any reason be held by a court of competent jurisdiction to be invalid, illegal, or unenforceable in any respect, such invalidity, illegality, or unenforceability shall not affect any other provision of the agreement, and this agreement shall be construed as if the invalid, illegal, or unenforceable provision had never been included in the Agreement. This agreement constitutes the sole and only agreement of the Parties to the Agreement and supersedes any prior understanding or written or oral agreements between the Parties respecting the subject matter of this agreement.

6.4 This agreement shall be governed and construed in accordance with the laws of the State of Texas, and all obligations of the parties created by this agreement are performable in Cameron County, Texas.

6.5 No party shall be required to perform any term, condition, or covenant in this agreement so long as performance is delayed or prevented by force majeure, which shall mean acts of God, strikes, lockouts, material or labor restrictions by any governmental authority, floods, and any other cause not reasonably within the control of the parties and which by the exercise of due diligence the parties are unable, wholly or in part, to prevent or overcome.

VII.

7.1 The parties indicate acceptance of each of the terms of this agreement by the signature of their respective agents below. The agents signing below each represent that they have been authorized by their respective parties to execute this agreement on their behalf. The effective date of this agreement shall be the latest of the dates appearing below.

EXECUTED IN DUPLICATE ORIGINAL on this ____ day of _____ 2018

Attachment: MOU LFPD LFCISDPD 2018 2019 [Revision 1] (2852 : MOU with School PD)

LOS FRESNOS CONSOLIDATED
INDEPENDENT SCHOOL
DISTRICT

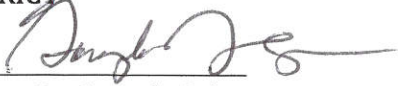
By: 
Dr. Gonzalo Salazar
Superintendent of Schools

CITY OF LOS FRESNOS,
TEXAS

By: _____
Mark Milum
City Administrator

LOS FRESNOS C.I.S.D.
DISTRICT POLICE

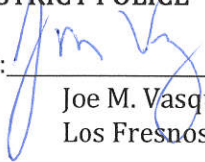
By: 
Joe M. Vasquez
Los Fresnos C.I.S.D., Chief of Police

LOS FRESNOS
POLICE DEPARTMENT

By: _____
Hector Gonzalez
City of Los Fresnos, Chief of Police

Attachment: MOU LFPD LFCISDPD 2018 2019 [Revision 1] (2852 : MOU with School PD)

THE STATE OF TEXAS '
'
ACKNOWLEDGMENT
COUNTY OF CAMERON '
'

This instrument was acknowledged before me on the 15 day of October, 2018, by Dr. Gonzalo Salazar, Superintendent of Schools, for and on behalf of the Los Fresnos Consolidated Independent School District.

Irma Ortega
Notary Public-State of Texas

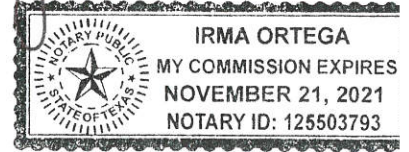

THE STATE OF TEXAS '
'
ACKNOWLEDGMENT
COUNTY OF CAMERON '
'

This instrument was acknowledged before me on the ___ day of _____ 2018, by Mark Milum, City Administrator of the City of Los Fresnos, Texas, for and on behalf of the City of Los Fresnos, Texas.

Notary Public-State of Texas

THE STATE OF TEXAS '
'
ACKNOWLEDGMENT
COUNTY OF CAMERON '
'

This instrument was acknowledged before me on the 15 day of October, 2018, by Joe M. Vasquez, Police of Chief, Los Fresnos Consolidated Independent School District.

Irma Ortega
Notary Public-State of Texas

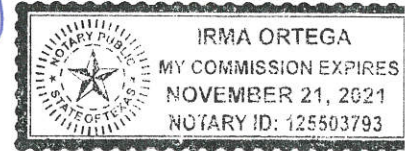

THE STATE OF TEXAS '
'
ACKNOWLEDGMENT
COUNTY OF CAMERON '
'

This instrument was acknowledged before me on the ___ day of _____ 2018, by Hector Gonzalez, Chief of Police, City of Los Fresnos, Texas, for and on behalf of the City of Los Fresnos, Texas.

Notary Public-State of Texas

Attachment: MOU LFPD LFCISDPD 2018 2019 [Revision 1] (2852 : MOU with School PD)

City Council
200 North Brazil
Los Fresnos, TX 78566

Meeting: 12/11/18 06:00 PM
Department: City Manager
Category: Change Order
Prepared By: Jacqueline Moya
Initiator: IQM2 Admin
Sponsors:
DOC ID: 2862 A

SCHEDULED

ACTION ITEM (ID # 2862)

Consideration and ACTION to acknowledge the City Manager's decision to utilize \$6,500 from the contingency fund for final stabilization.

The work done for the stabilization of the ground for the city hall site worked in all areas except 3 areas along the edges. The engineer recommended \$6,500 worth of cement to be added to complete the stabilization. Due to the weather and the need to get this completed quickly I approved to move forward. It is not a change in the contract as these funds come from the contingency fund in the contract which is why I could approve it. I am placing it on the agenda for approval to keep the Council up to date with where we are. If it was a change in the contract, we would not have the flexibility for me to approve. It could only be approved by the Council. The stabilization worked and the compaction of the foundation continues.

I recommend approval.



McAllen • San Antonio

P.O. Box 3455
McAllen, TX 78502-3455
Ph : (956) 686-9573

Change Request

To: Brown Reynolds Watford Archite
2700 Earl Rudder Frwy S, #400
College Station, TX 77845
Ph: 979-694-1791

Number: 02
Date: 11/27/18
Job: 18-051 Los Fresnos City Hall
Phone:

Description: Additional Cement at the building pad

Reason: Unforeseen Condition

Source: Other

We are pleased to offer the following specifications and pricing to make the following changes
additional Cement at the building pad

Description	Labor	Material	Equipment	Subcontract	Other	Price
Sitework contractor - Additional Cement at Bldg Pad subgrade				\$6,500.00		\$6,500.00
					Subtotal:	\$6,500.00
					Total:	\$6,500.00

If you have any questions, please contact me at .

Attachment: 18051-CR 02 -additional Cement at the building pad (2862 : Change Order New City Hall)

Submitted by:

Approved by: _____

Date: _____

PEDERSON CONSTRUCTION

To: *D. Wilson Construction*

DATE 11/26/18

Project *Los Fresnos City Hall*

Phone 956-369-7805

Ref: **Cement
Breakdown**

Attn. Claudio

QTY	UNIT	Materials	Unit Price	Amount
10	ton	cement	\$ 180.00	\$ 1,800.00
MATERIAL COST				\$ 1,800.00

QTY	UNIT	Labor Clasification	Average Direct Rate	Amount
5	HR	1 Common labor	\$ 12.50	\$ 62.50
5	HR	motor graader operator	\$ 24.75	\$ 123.75
5	HR	excavator operator	\$ 23.50	\$ 117.50
5	HR	water tank operator	\$ 17.50	\$ 87.50
5	HR	Mixer opertor	\$ 18.75	\$ 93.75
5	HR	sheeps foot operator	\$ 18.75	\$ 93.75
5	HR	drum compactor operator	\$ 18.75	\$ 93.75
5	HR	forman	\$ 35.00	\$ 175.00
0.75	HR	superintendent	\$ 45.00	\$ 33.75
0.25	HR	project manager	\$ 50.00	\$ 12.50
				\$ 893.75
PRODUCTION / DAY			1	
DIRECT LABOR COST				\$ 893.75

QTY	UNIT	EQUIPMENT	Rate	Amount
5	HR	motor grader 30,000lbs	\$ 104.00	\$ 520.00
5	HR	excavator	\$ 97.00	\$ 485.00
5	HR	water tank 5000 gal	\$ 50.00	\$ 250.00
5	HR	mixer 310 hp	\$ 80.00	\$ 400.00
5	HR	Sheep foot 130 hp	\$ 60.00	\$ 300.00
5	HR	drum roller	\$ 60.00	\$ 300.00
5	HR	portable light	\$ 28.00	\$ 140.00
5	HR	pk truck	\$ 18.50	\$ 92.50
				\$ 2,487.50

PRODUCTION / DAY 1
DIRECT EQUIPMENT COST \$ 2,487.50

TOTAL MATERIAL \$ 1,800.00
TOTAL LABOR \$ 893.75
TOTAL EQUIPMENT \$ 2,487.50

MATERIAL OVERHEAD AND PROFIT 15% \$ 270.00
LABOR OVERHEAD AND PROFIT 25% \$ 223.44
INSURANCE AND TAXES 55% \$ 491.56
EQUIPMENT OVERHEAD AND PROFIT 15% \$ 373.13

TOTAL \$ 6,539.38

Attachment: 18051-CR 02 -additional Cement at the building pad (2862 : Change Order New City Hall)

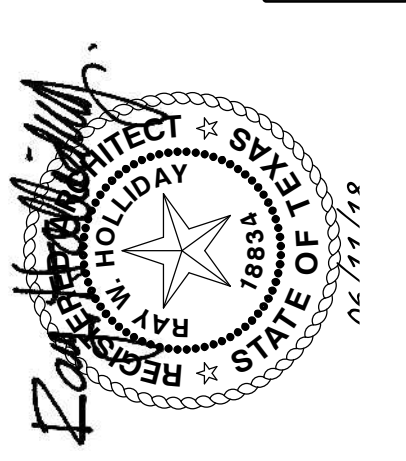

BROWN REYNOLDS WATFORD ARCHITECTS, INC. 2700 EARL BURDER FERRY SOUTH SUITE 400 DALLAS, TEXAS 77245 972.694.1791 WWW.BRWARCH.COM

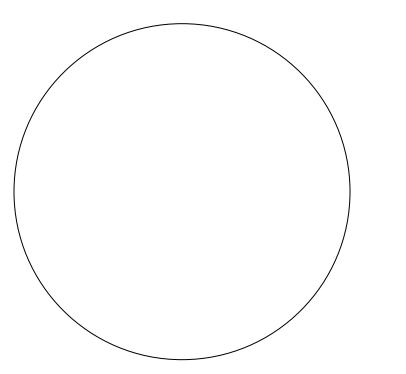

COPYRIGHT © 2018 BROWN REYNOLDS WATFORD ARCHITECTS, INC. DATE 06/11/18 DRAWN BY JW, JH, DP CHECKED BY MW, RH BRW PROJECT NUMBER 21707200 Attachment: 88051-CR 02-additional Cement at the building pad (2882 - Change Order New City Hall)

LOS FRESNOS CITY HALL 520 EAST OCEAN BLVD LOS FRESNOS, TX 78566

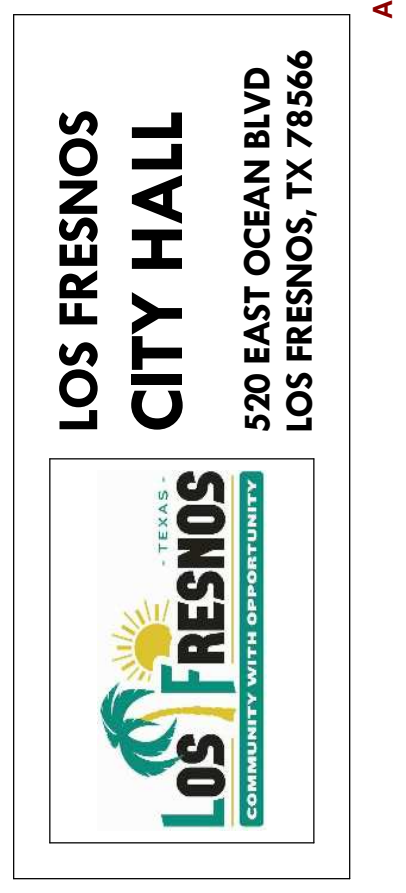

Table with columns: NO., REVISION, ADDENDUM NO., DATE. Row 1: 1, 4, 7/17/18

C1.1

KEYNOTES

- 0220.01 EXISTING TREE
0220.02 EXISTING LIGHT POLE
0220.03 EXISTING POWER POLE
0220.05 EXISTING ASPHALT PAVING
0220.08 EXISTING CONCRETE SIDEWALK
0220.10 EXISTING FIRE HYDRANT
0220.14 EXISTING MANHOLE COVER
0220.16 EXISTING STORM WATER INLET
0220.55 EXISTING COMMUNICATIONS VAULT
0220.56 EXISTING CULVERT
0550.11 4" X 4" X 1/4" STEEL TUBE
0550.19 6" PIPE BOLLARD WITH PRECAST CONCRETE CAP, FILL WITH CONCRETE
0550.67 4" X 2" X 1/4" STEEL TUBE GATE FRAME
0550.68 6" X 6" X 1/4" STEEL TUBE
0760.34 METAL DOWNSPOUT ADAPTER
0770.18 CONCRETE SPLASH BLOCK
1010.33 POLE MOUNTED SIGNAGE - "H.C. PARKING ONLY"
1010.35 POLE MOUNTED SIGNAGE - "DO NOT ENTER"
2630.01 EMERGENCY GENERATOR
2650.17 LIGHT POLE / FIXTURE ON CONCRETE BASE
2650.20 LIGHT BOLLARD
3210.14 CONCRETE PAVING (RE. CIVIL)
3210.15 CONCRETE APPROACH PER CITY REQUIREMENTS
3210.18 CONCRETE GENERATOR PAD
3210.22 PAVING EXPANSION JOINT - FILL WITH JOINT SEALER 1/4" BELOW SURFACE
3210.24 PRE-CAST CONCRETE PAVING UNITS WITH TRUNCATED DOMES (ADA COMPLIANT)
3210.30 6" CONCRETE CURB (WITH GUTTER AS REQUIRED) (RE. CIVIL)
3210.33 4" PAVEMENT MARKING
3210.34 H.C. PAVEMENT MARKING
3210.35 FIRE LANE STRIPING PER CITY REQUIREMENTS
3210.36 DIRECTIONAL PAVEMENT MARKING
3210.37 WHEEL STOP (6'-0" LONG), DRILL AND DOWEL INTO PAVING
3210.39 CONCRETE SIDEWALK (RE. CIVIL)
3210.41 SAW CUT CONTROL JOINT
3210.46 4" PAVEMENT MARKING WITH DIAGONAL STRIPING AT 2'-0" O.C.
3230.54 1 X 8 COMPOSITE DECK BOARD
3280.03 IRRIGATION BACKFLOW PREVENTER AND ENCLOSURE
3340.19 6" PVC PIPE, CONNECT TO DOWNSPOUT ADAPTER AND SLOPE 1/4" PER FOOT MIN. TRANSFORMER WITH CONCRETE PAD PER POWER COMPANY REQUIREMENTS
3370.07 ELECTRIC METER, CT GAN. AND MAIN DISCONNECT PER POWER COMPANY REQUIREMENTS
3380.05 IN-GROUND COMMUNICATIONS PULL BOX

GENERAL NOTES

- 1. DIMENSIONS ARE TO OUTSIDE FACE (BACK) OF CURB UNLESS OTHERWISE NOTED.
2. CONCRETE SHALL HAVE A MINIMUM 28-DAY COMPRESSIVE STRENGTH OF 4,000 PSI.

LEGEND

Table with columns: SYMBOL, DESCRIPTION. Includes symbols for existing to remain, 7" concrete paving, 5" concrete paving, and 4" concrete sidewalk.

BID ALTERNATES

- SEE SPECIFICATION SECTION 01 23 00 ALTERNATES FOR ADDITIONAL INFORMATION
ALT. 1: DELETE LANDSCAPING & IRRIGATION
ALT. 2: DELETE OUTDOOR PLAZA
ALT. 3: DELETE ONE DRIVE THRU LANE
ALT. 4: CHANGE CONCRETE PAVING TO ASPHALT
ALT. 5: CHANGE FENCE FROM COMPOSITE TO CEDAR
ALT. 6: CHANGE MEDALLIONS TO A SINGLE DESIGN
ALT. 7: CHANGE MANUFACTURED STONE TO STUCCO
ALT. 8: CHANGE METAL ROOF TO ASPHALT SHINGLES
ALT. 9: DELETE COILING SECURITY GRILLES
ALT. 10: DELETE LIGHTNING PROTECTION SYSTEM
ALT. 11: CHANGE LED LIGHTING TO FLUORESCENT
ALT. 12: DELETE BACKUP GENERATOR & ATS

E OCEAN BLVD. (TX 100)

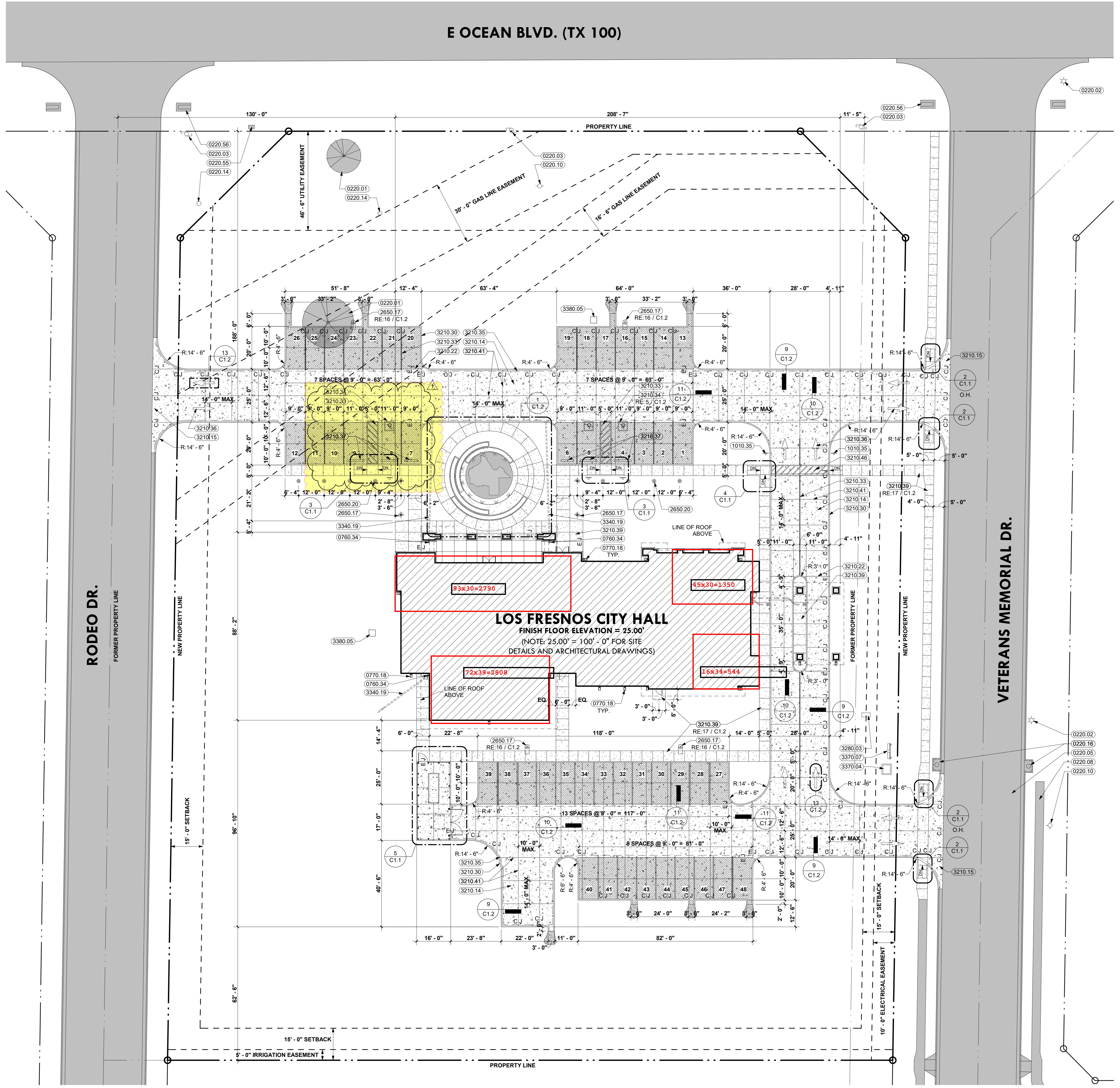

RODEO DR. FORMER PROPERTY LINE

VETERANS MEMORIAL DR.

LOS FRESNOS CITY HALL FINISH FLOOR ELEVATION = 25.00' (NOTE: 25.00' = 100'-0" FOR SITE DETAILS AND ARCHITECTURAL DRAWINGS)

2 SITE RAMP PLAN

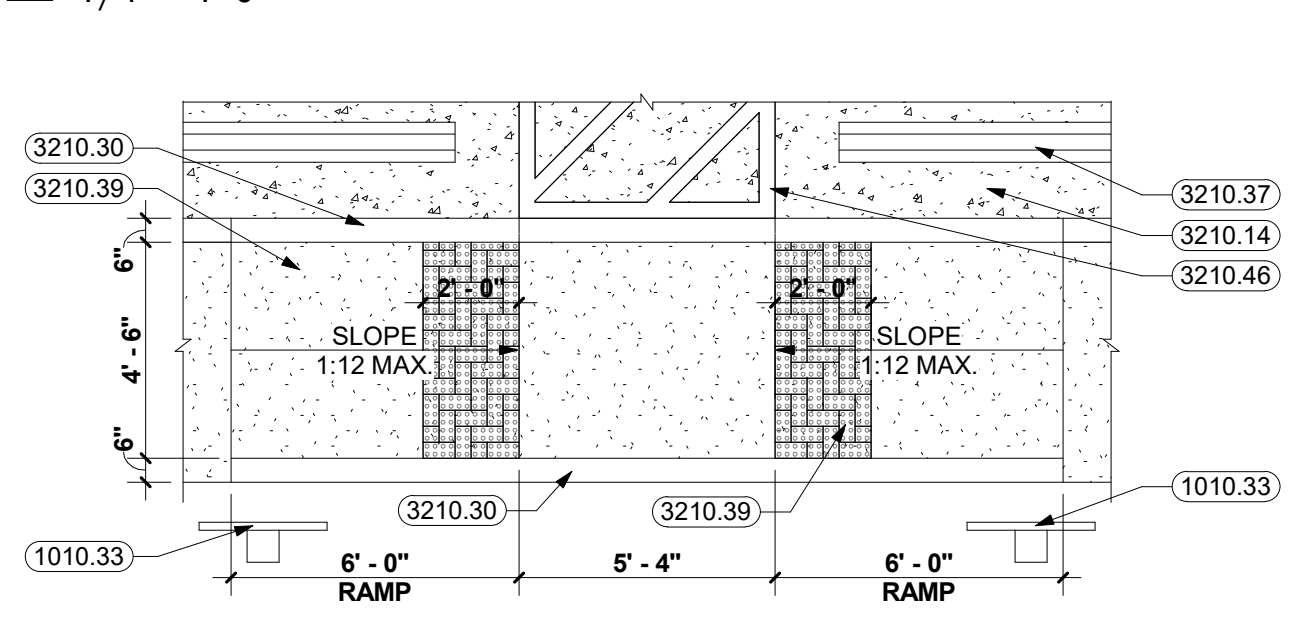

3 DUAL SITE RAMP

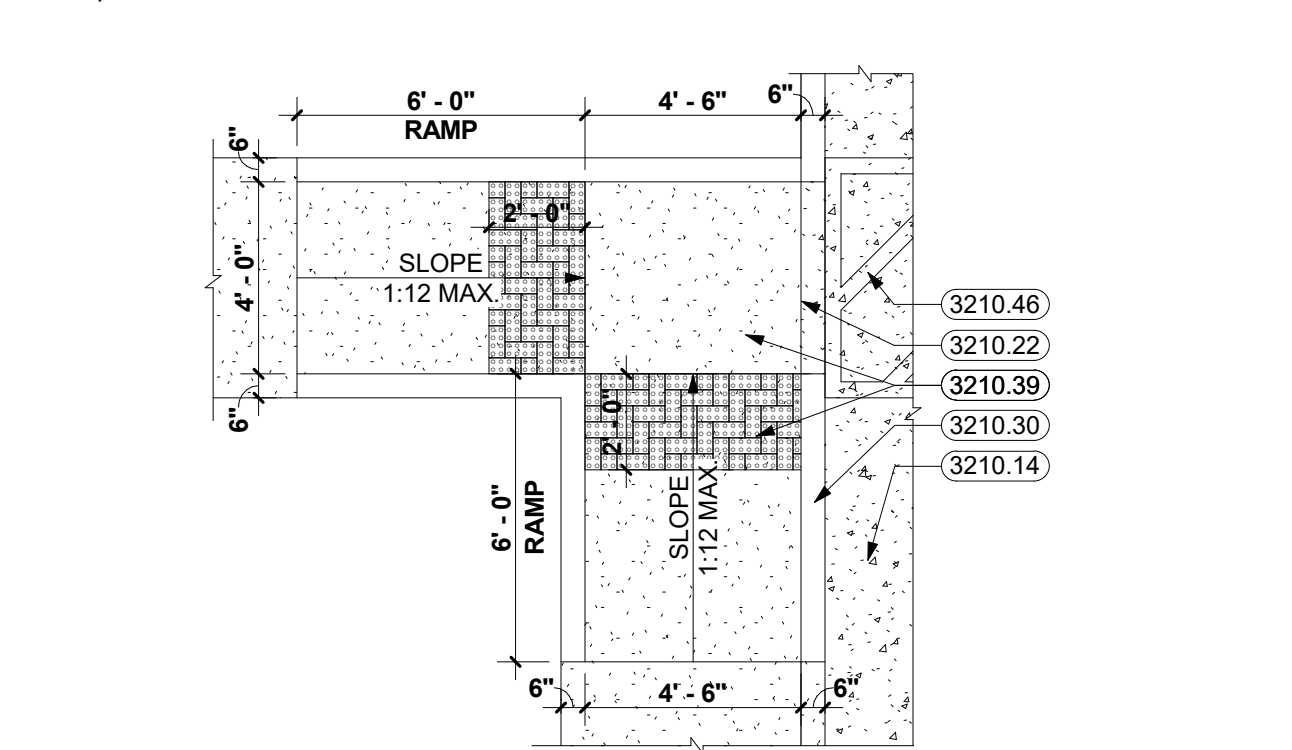

4 DUAL SITE RAMP

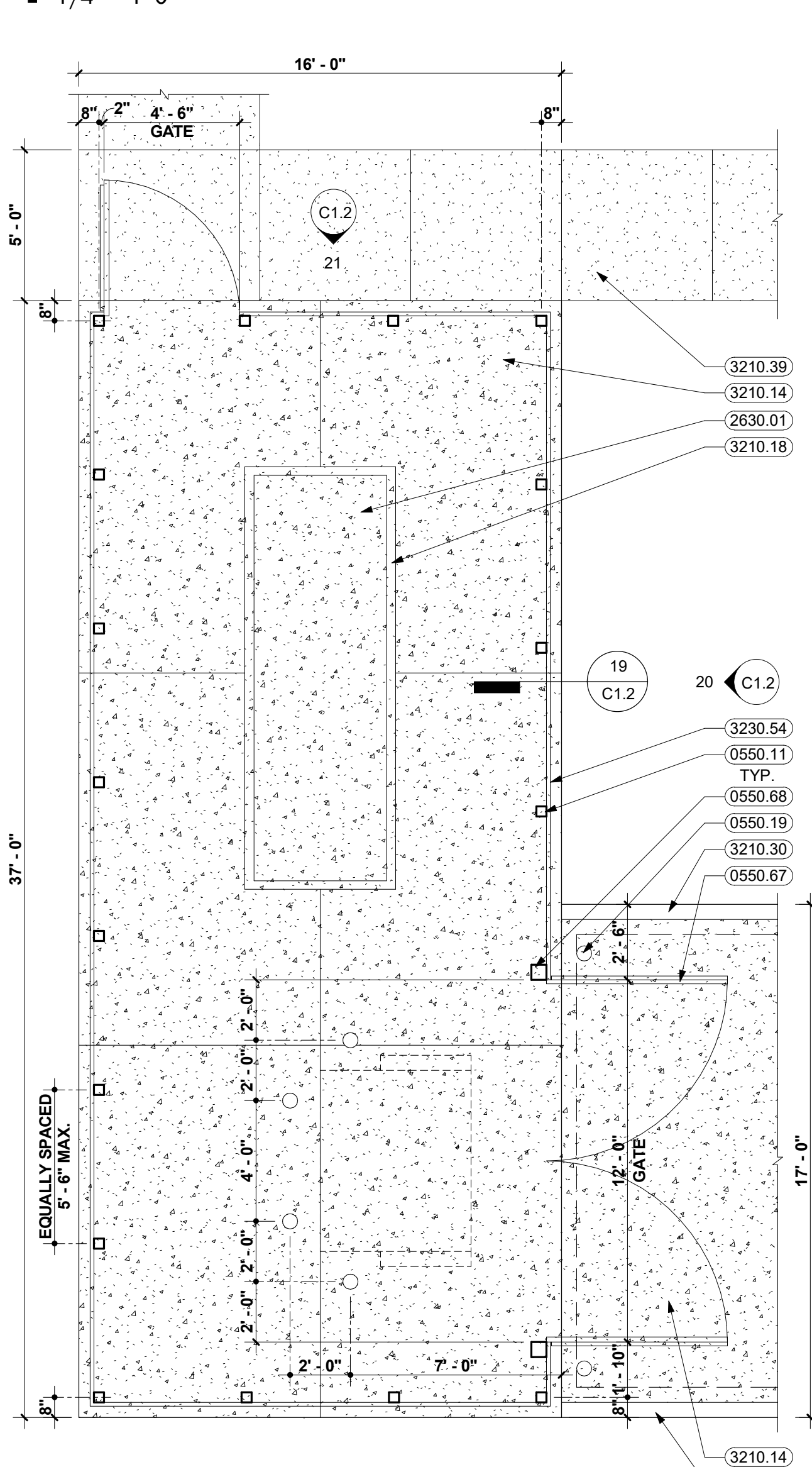

5 DUMPSTER ENCLOSURE PLAN



1 SITE PLAN

1" = 20'-0"



City Council
200 North Brazil
Los Fresnos, TX 78566

Meeting: 12/11/18 06:00 PM
Department: City Secretary
Category: Policy
Prepared By: Jacqueline Moya
Initiator: Jacqueline Moya
Sponsors:
DOC ID: 2858 A

SCHEDULED

ACTION ITEM (ID # 2858)

Consideration and ACTION to approve Los Fresnos Police Department Policies.

As we continually review policies and update as needed, this is an update on our policy dealing with cameras in the patrol units as well as the cameras worn on the officers themselves. These policies are developed through the Texas Police Chiefs Association Best Practices reviewed by attorneys specializing in this. As our Command Staff of the Police Department reviews these, they make adjustments if necessary to fit our department without compromising the content as intended. Cameras have become an important piece of evidence that protects the person the officer makes contact with as well as the officers themselves.

I recommend approval.

	<p>Los Fresnos Police Department General Order</p>
	<p>MOBILE AUDIO/VIDEO RECORDING SYSTEMS AND BODY WORN CAMERAS</p>
	<p>General Order 49</p>
	<p>Hector Gonzalez Chief of Police</p>

Attachment: LFPD POLICY MOBILE AUDIO VIDEO RECORDING SYSTEM (2858 : LFPD-Policies)

Subject: MOBILE AUDIO/VIDEO RECORDING SYSTEMS AND BODY WORN CAMERAS

Section 49.01 PURPOSE

This policy was created to provide guidelines and procedures for use, maintenance, and management of the mobile audio/video recordings systems and body worn camera equipment.

- A. The Los Fresnos Police Department is dedicated to utilizing body worn cameras in a manner that is fair and equitable to both citizens and employees.
- B. The use of body worn cameras is intended to accomplish the goals of:
 - 1. Enhance Department transparency to the public.
 - 2. Enhancement of officer safety.
 - 3. Enhancement of officer reporting, evidence collection, and court testimony.
 - 4. Enhance officer training.
 - 5. Protection from false claims of impropriety.
 - 6. Provide accurate documentation of events, actions, conditions, and statements made during arrests and critical incidents.
 - 7. Document the quality of service provided by police officers.
- C. The Body worn camera recordings will be used for legitimate law enforcement purposes only and in accordance with applicable law and Departmental policies.

Section 49.02 POLICY

- A. It is the policy of the Los Fresnos Police Department that officers shall activate mobile audio/video recording equipment and body worn cameras when such use is appropriate to the proper performance of their official duties, and that audio/video evidence of

traffic and other law violations be available to present for prosecution. To this end, officers with properly functioning body worn camera equipment shall record all events surrounding the contact, stop, detention, interview and arrest of suspected violators and maintain this recorded evidence for consideration in criminal prosecution and internal investigations.

- B. All recordings generated on department-owned mobile audio/video recording equipment and body worn camera equipment are the property of the Los Fresnos Police Department. The copying or reproducing of any recordings generated by members of the department for use outside of departmental business is prohibited. A Los Fresnos Police Department supervisor will process requests for copies.
- C. Distribution of any recordings generated by department members in any format or for any purpose must be in compliance with this procedure and legal guidelines. Release of any recording created with a body worn camera by any officer, without the permission of the Los Fresnos Police Department, is a violation of Section 1 701.659 of the Texas Occupations Code, as amended.

Section 49.03 DEFINITIONS

- A. Mobile audio/video recording equipment- refers to a device mounted in a vehicle which capable of recording both audio and video.
- B. Body Worn Camera Equipment- refers to a recording device that is capable of recording or transmitting to be recorded remotely, video or audio and worn on the person of a peace officer, which includes being attached to the officers clothing.
- C. Video- refers to both video and audio recorded by either mobile audio/video recording equipment or body worn camera equipment.

Section 49.04 MAINTENANCE OF EQUIPMENT

- A. All members of the Los Fresnos Police Department shall ensure that mobile audio/video recording equipment and body worn cameras are maintained in a state of operational readiness. Equipment malfunctions will be brought to the attention of a supervisor as soon as possible. Damaged body worn cameras will be returned to his/her supervisor.
- B. Officers shall be issued a body worn camera as well as the device's associated accessories. It will be the officer's responsibility to ensure the body worn camera device is fully charged and operable prior to their tour of duty. Body worn cameras are the responsibility of the individual officer and will be used with reasonable care to ensure proper functioning.
- C. No officer shall alter, modify, reuse, tamper with or disable the body worn camera or associated accessories in any manner. Department body worn camera equipment shall not be connected to an unauthorized computer, nor shall non-department-issued equipment be connected to any department-issued body worn camera device.

- D. Employees shall use departmental equipment in accordance with established departmental procedures and directives. Employees shall not, intentionally or through negligence, abuse, damage, or lose departmental equipment. Loss, theft, or severe damage to body worn camera equipment will be documented by the officers in an incident report and will be immediately reported to a supervisor. The supervisor will ensure that the incident report has been completed, and will draft a memo to the Chief of Police. In this memo the supervisor will make a recommendation regarding whether the officer should be required to make restitution.
- E. Officers who leave the department, or who are reassigned to duties where they will not be utilizing the body worn camera equipment, will return any body worn camera in their possession to a supervisor. The supervisor will ensure that the proper equipment issue form is completed and the placed in the officer's file.

Section 49.05 OFF DUTY USE OF BODY WORN CAMERA EQUIPMENT

Officers working extra employment within our jurisdiction will use their body worn camera while work extra employment if the employment is police- or security-related and approved by the department, but only in compliance with the Los Fresnos Police Department general orders and legal standards. Officers will download all evidence recorded during their off-duty employment no later than during their next regularly assigned on-duty shift or when directed by a supervisor.

Section 49.06 BODY WORN CAMERA EQUIPMENT TRAINING

- A. Officers who utilize a body worn camera, and any other personnel who will come into contact with audio/video data obtained from a body worn camera, shall complete an agency approved and/or provided training program to ensure proper use and operation.
- B. Additional training may be required at periodic intervals to ensure the continued effective use and operation of the equipment, performance, and to incorporate changes, updates, or other revisions in policy and equipment.

Section 49.07 MOBILE AUDIO/VIDEO EQUIPMENT PROCEDURES

- A. Officers assigned to patrol vehicles equipped with mobile audio/video recording systems shall adhere to the following listed procedures:
 1. The officer shall carry the microphone/transmitter on his/her person and shall ensure that the transmitter and receiver are set to the same frequency and working properly.
 2. Officers will inspect and test the body worn camera prior to each shift in order to verify proper functioning. Officers will also ensure that the clip is in good condition and that the body camera worn camera is securely affixed to the officer's uniform.
 3. Officers shall not intentionally direct a person out of the camera's field of view to avoid having the contact visually recorded or turn off the transmitter while contact is being made.

4. Officers shall not erase, destroy, record over, tamper with, make an unauthorized copy, or otherwise alter an audio/video recording obtained from department mobile audio/visual recording equipment.
 5. Citizens may not view mobile audio/video recordings in the field.
- D. Officers assigned to patrol vehicles equipped with mobile audio/video recording systems shall activate their audio and video recording systems when responding to and under the following conditions:
1. All officer-initiated enforcement and investigative contacts to include traffic and pedestrian stops and field interviews.
 2. Anytime the officer's emergency lighting is activated while responding to a call for service.
 3. Any criminal investigation where the initial response required the activation of emergency lights and/or siren.
 4. Anytime an officer is in contact with a citizen or suspect when it is feasible that the video system may record all or part of the contact.
 5. Any officer involved in a fleet collision shall, unless physically unable to, immediately activate their video and audio recording system.
 6. Any contact that becomes adversarial after the initial contact in a situation that would not otherwise require recording.
 7. Any situation that the officer believes may be later called into question, or where mobile audio/video recording equipment footage would aid in the resolution of a citizen complaint.

Section 49.08 **WHEN BODY WORN CAMERA WILL BE ACTIVATED**

- A. While no officer shall be required to keep a body worn camera activated the entire shift, officers shall activate their body worn camera to record all contacts that are conducted within the scope of an official law enforcement capacity, including but not limited to:
1. Before any enforcement stop, pedestrian or vehicle, officers will activate the body camera upon exiting the police vehicle. An officer may activate the camera any time prior to exiting the vehicle. If the BWC cannot be activated upon exiting the police vehicle, it will be activated as soon as practical and safe to do so.
 2. Upon arrival when on any call for service. Officers may activate the camera while enroute to a call destination if they deem it necessary.
 3. During non-vehicle pursuits (foot, bike, etc.) as soon as the officer can do so safely.
 4. During vehicle pursuits in vehicles without in-car DVR systems, as soon as the officer can do so safely.
 5. Upon arriving to all crime in progress calls as soon as the officer can do so safely.
 6. During the execution of a warrant or "knock and talk" operation.
 7. When requesting and conducting a consensual search of any type.
 8. Before any planned or anticipated arrest.

9. During the inventorying of seized narcotics, money, or any high value property.
 10. During the inventorying of any vehicle that is being impounded.
 11. When conducting the Standard Field Sobriety Test (SFST) or Drug Recognition Expert (DRE) test.
 12. Any situation where the officer's training and experience causes him/her to believe the incident needs to be recorded to enhance reports, preservation of evidence, and aid in subsequent court testimony.
 13. Any time an officer deems necessary.
 14. Any situation that the officer believes may be later called into question, or where body worn camera footage would aid in the resolution of a citizen complaint.
 15. Any incident or contact that may result in an enforcement action being taken or official report being generated.
- B. Any decision not to activate the body worn camera because it is unsafe, unrealistic, or impracticable will be based on whether a reasonable officer under the same or similar circumstances would have made the same decision.
- C. If an officer fails to activate the body worn camera, fails to record the entire contact, or interrupts the recording, or in the event of equipment malfunction, the officer will document why a recording was not made, was interrupted, or was terminated in the officer's report, supplemental report, or call for service.

Section 49.09 USE OF BODY WORN CAMERA EQUIPMENT PROHIBITED

Officers are required to be responsible in their use of audio/visual recording devices and to avoid recording in places where it would be inappropriate or prohibited by law. As such, no officer shall:

- A. Record or monitor another member without the second member having prior knowledge that he/she is being recorded or monitored. However, the Chief of Police or his/her designee may authorize exceptions for just cause or during internal/criminal investigations. Members shall assume that audio and/or visual recording equipment is activated under the following circumstances:
 1. While transmitting on a departmental radio channel.
 2. While speaking on a departmental telephone.
 3. While responding as a cover officer to a call for service, traffic or pedestrian stop, offense scene or other incident that would require the initial responding officer to activate his/her body worn camera.
 4. While in the vicinity of a Patrol Vehicle equipped with a video camera system.
- B. Use departmental audio and/or visual recording equipment for his/her personal use.
- C. Intentionally create recordings of themselves or other employees in areas where a reasonable expectation of privacy exists such as locker rooms, restrooms, etc.
- D. Knowingly record undercover officers or confidential informants.
- E. Allow citizens to view the body worn camera recordings in the field.
- F. Allow non-sworn individuals to view body worn camera recordings without permission from the officer's immediate supervisor. Governmental employees who are directly involved in the investigation and/or prosecution of a criminal case related to the body worn

camera video or who work in Internal Affairs or IT Services supporting body worn camera are exempt from this provision.

- G. Create recordings in patient care areas of medical facilities unless the recording is for official police business such as a criminal investigation, dying declaration, Horizontal Gaze Nystagmus (HGN) on injured drivers, or a specific call for police service; in compliance with Federal HIPPA regulations.

Section 49.10 DEACTIVATION

Officers may deactivate mobile audio/visual recording equipment or body worn camera, or discontinue recording, under the following circumstances:

- A. When the officer reasonably believes the privacy of the individual being recorded outweighs the needs of the state.
- B. At the conclusion of the precipitating event.
- C. When the event includes an extended contact that is not confrontational (including an interview with a witness or victim).
- D. When the event includes an extended perimeter, or on a prolonged event that is not of an adversarial nature.
- E. In those instances when an officer deactivates mobile audio/video recording equipment or body worn camera equipment as described above, they should be mindful to resume the recording as soon as practical if necessary.
- F. Officers shall not discontinue the use of the body worn camera once it is in use if dictated by this policy to record.

Section 49.11 USE OF PERSONAL RECORDING EQUIPMENT WHILE ON DUTY

Members may not use personal audio and/or visual recording equipment while on duty.

Section 49.12 RELEASE OF RECORDINGS

Recordings made using mobile audio/video equipment or body worn cameras pursuant to this policy are department records and may only be released as provided by the Texas Public Information Act or for other authorized legitimate department business purposes. Release of body worn camera recordings shall conform to the guidelines established in Texas Occupations Code 1701 .661.

Section 49.13 DATA STORAGE AND RETENTION

A. Mobile audio/video recording equipment

- 1. After the creation of a recording, officers shall be responsible for classifying the recording as one of the following:
 - a. Traffic Stop with Citation;
 - b. Traffic Stop with No Citation;
 - c. Arrest;
 - d. Junk/Test;
 - e. Pedestrian Contact;
 - f. Pursuit;

Attachment: LFPD POLICY MOBILE AUDIO VIDEO RECORDING SYSTEM (2858 : LFPD-Policies)

- g. Search/Consent/impound;
 - h. Use of Force;
 - i. Call for Service; or
 - j. FTA / Warrant traffic stop.
2. All recordings shall be retained for a period of not less than 90 days.
 3. Recordings classified as Traffic Stop with No Citation, Junk/Test, Pedestrian Contact Search/Consent/impound, Call for Service, or FTA / Warrant traffic stop shall be purged after 90 days.
 4. Recordings classified as Traffic Stop with Citation, Arrest, Pursuit, or Use of Force shall be maintained until the conclusion of any legal or administrative investigations.

B. Body Worn Camera Equipment

1. Unless authorized by a Corporal or above, body worn camera video shall be downloaded at the conclusion of the officer's shift.
 2. Officers shall be responsible for classifying each recording as one of the following:
 - a. Traffic Stop with Citation;
 - b. Traffic Stop with No Citation;
 - c. Arrest;
 - d. Junk/Test;
 - e. Pedestrian Contact;
 - f. Pursuit;
 - g. Search/Consent/impound;
 - h. Use of Force;
 - i. Call for Service; or
 - j. FTA / Warrant traffic stop.
 3. Supervisors shall perform daily checks of uploaded video to ensure that each recording has been assigned a classification.
- C. In some situations, the supervisor may deem it necessary to take physical custody of the mobile audio/video recording equipment and/or body worn camera hard drive for preservation. It will be the supervisor's responsibility to maintain the integrity of the device(s) once seized and unload the video to the video recording system. These situations may include, but are not limited to:
1. Officer involved shootings;
 2. In custody deaths;
 3. Incidents involving an officer that result in death or serious bodily injury to a person
 4. Fleet crashes where the unit is disabled; or
 5. Officers otherwise not able to upload their recorded video to the video recording system.

Section 49.14 SUPERVISORY RESPONSIBILITIES

- A. Weekly, supervisors will review at least one body worn camera and, if applicable, on mobile audio/video recording for each officer they supervise. Supervisors will record the following in the camera audit log
 - 1. The officer whose camera recording was reviewed;
 - 2. The date of the review;
 - 3. The type of camera recording (body worn camera or mobile audio/video);
 - 4. Incident type; and
 - 5. Supervisor name.
- B. Minor Infractions (not criminal in nature) discovered during the routine review of recorded material should be viewed as training opportunities and not as routine disciplinary actions. Should the behavior or action become habitual after being informally addressed, appropriate disciplinary or corrective action shall be taken.
- C. Supervisory personnel who manage employees using body worn cameras and mobile audio/video recording equipment shall ensure that:
 - 1. Employees shall follow established procedures for the use and operation of body worn cameras and mobile audio/video recording equipment, handling of video recordings, and the completion of data transfer and documentation.
 - 2. All videos are uploaded prior to the end of shift. No videos are to be left on a body worn camera at the completion of an officer's shift.
 - 3. The need for repairs and or replacement of damaged or nonfunctional body worn cameras is reported and actions are taken to repair or replace these pieces of equipment.

Section 49.15 REVIEW OF RECORDINGS

- A. When preparing written reports, officers are encouraged to review mobile audio/video and body worn camera recordings as a resource to ensure the accuracy and consistency of the report.
- B. Mobile video and body worn camera recordings are not a substitute for required written reports.
- C. Members shall not retain personal copies of any recordings.
- D. Officers shall be given access to any recording of an incident involving the officer before the officer is required to make a formal statement.
- E. Supervisors are authorized to review relevant recordings:
 - 1. Any time they are investigating alleged misconduct or reports of meritorious conduct
 - 2. Whenever such recordings would be beneficial in reviewing an officer's performance
 - 3. Periodically, for the purpose of verifying compliance with this policy or legal requirements.
- F. Recorded files may also be reviewed:

1. By officers for the purpose of ensuring that recordings are properly categorized for retention.
2. Pursuant to lawful process or by court personnel who are otherwise authorized to review evidence in a related case.
3. By media personnel with permission of the Chief of Police
4. In compliance with the Texas Public Information Act.

City Council
200 North Brazil
Los Fresnos, TX 78566

Meeting: 12/11/18 06:00 PM
Department: City Secretary
Category: Resolutions
Prepared By: Jacqueline Moya
Initiator: Jacqueline Moya
Sponsors:

SCHEDULED

ACTION ITEM (ID # 2860)

DOC ID: 2860 A

Discuss, consider, and adopt resolution designating an engineering service provider to complete application and project related engineering services for the Texas Department of Agriculture's 2019-2020 TxCDBG Community Development fund.

The next round of TDA, CDBG funding is approaching. The Council previously selected Grant Works as our grant administrator. Now we need to select the engineer for the project. The project has not been selected yet but we will have a recommendation. As normal the Mayor selected 2 Council Members to rate the 4 firms that we received proposals from. The rating scores are attached. The highest rating firm is Hanson Professional Services. The fees are set by TDA so we don't have to negotiate that like we normally do with some engineering services.

I recommend approval of Hanson Professional Services as the engineering service provider to complete the application and project related engineering services to the TDA 2019-2020 TxCDBG Community Development fund.

RESOLUTION 17-2018

A RESOLUTION OF The City of Los Fresnos, TEXAS, AUTHORIZING THE AWARD OF A PROFESSIONAL SERVICE PROVIDER CONTRACT FOR THE TEXAS COMMUNITY DEVELOPMENT BLOCK GRANT (TxCDBG) 2019-2020 TxCDBG Community Development Fund PROJECT.

This Resolution was introduced and submitted to the City Council for passage and adoption. After presentation and discussion of the Resolution, a motion was made by _____ that the Resolution be finally passed and adopted in accordance with the City’s Home Rule Charter. The motion was seconded by _____ and carried by the following vote:

Mayor Polo Narvaez	___	For	___	Against	___	Abstained
Mayor Pro-tem Yolanda H. Cruz	___	For	___	Against	___	Abstained
Councilmember Swain Real	___	For	___	Against	___	Abstained
Councilmember James Herrera	___	For	___	Against	___	Abstained
Councilmember Joe Collinsworth	___	For	___	Against	___	Abstained
Councilmember Juan Munoz	___	For	___	Against	___	Abstained

WHEREAS, the 2019-2020 TxCDBG Community Development Fund contract requires implementation by professionals experienced in federally-funded community development projects;

WHEREAS, in order to identify qualified and responsive providers for these services a Request for Qualifications (RFQ) for engineering services has been completed in accordance with TxCDBG requirements;

WHEREAS, the proposals received by the due date have been reviewed to determine the most qualified and responsive providers for each professional service giving consideration to ability to perform successfully under the terms and conditions of the proposed procurement, integrity, compliance with public policy, record of past performance, and financial and technical resources

NOW, THEREFORE, BE IT RESOLVED:

- Section 1. That Hanson Professional Services be selected to provide Texas CDBG application and project-related **professional engineering services** for the 2019-2020 TxCDBG Community Development Fund project.
- Section 2. That any and all project-related services contracts or commitments made with the above-named service provider are dependent on the award of 2019-2020 TxCDBG Community Development funds and successful negotiation of a contract with the service provider.

Attachment: Resolution 17-2018 (2860 : Resolution 17-2018)

PASSED AND APPROVED by the City Council on this ____ day of _____, 2018.

APPROVED:

Polo Narvaez, Mayor

ATTEST:

Jacqueline Moya, City Secretary

Attachment: Resolution 17-2018 (2860 : Resolution 17-2018)

RATING SHEET FOR ENGINEERING SERVICES

COMPANY NAME	RATING BY SWAIN REAL	RATING BY YOLANDA CRUZ	RATING BY CARLOS SALAZAR	RATING BY JACQUELINE MOYA	TOTAL	AVERAGE
SAMES - Sam Engineering & Surveying	74	90	77	80	321	80.3
LEMC, LLC	83	73	90	87	333	83.3
Ambiotec Civil Engineering Group	79	98	93	83	353	88.3
Hanson Professional Services	88	100	95	98	381	95.3

City Council
200 North Brazil
Los Fresnos, TX 78566

Meeting: 12/11/18 06:00 PM
Department: City Secretary
Category: Bid
Prepared By: Jacqueline Moya
Initiator: Jacqueline Moya
Sponsors:

SCHEDULED

ACTION ITEM (ID # 2861)

DOC ID: 2861 A

Consideration and ACTION to award bid for TxCDBG State Contract 7217269 contingent on TDA approval of Amendment #1.

Bids were received for the drainage project through funding from TDA, TxCDBG. As you can see there are a lot of options. We do this so we can make the best decision with the amount of funding available. The base bid of \$56,410.00 is for the drainage upgrades along the irrigation canal at the end of Ash Street, Ebony Street and Pecan Street. The Additive Number 1 is the drainage upgrades for the flooding issues on East 7th Street from the culdesac back to Ebano Street. The Alternate Number 1 is redoing the entire street instead of patching it thus causing problems later on. We will have a new street. Approving this will leave \$53,543.86 in grant funds available. As soon as TDA approves this we will request the remaining funds to be utilized on the repaving of Ash Street since it is where some to the drainage work will be done on the base bid. Ash Street is in desperate need of being totally redone. The only piece that we will not be able to do because there are not enough funds is the Olmo Street drainage. This would have place the open drainage ditch underground from Eighth Street to past Tenth Street. Being an open ditch does not cause any drainage problems so it is not necessary. The reason to do it would be for better looks, possibly a little safer, but mostly for saving on maintenance on mowing that cost about \$300 per mowing. At a cost of \$216,717.67 we can mow it over 700 times before it cost that much. As it is we probably only need it mowed about 4-6 times a year.

I recommend approval of G&T Paving as the low bidder for the base bid in the amount of \$56,410 plus the Additie Number 1 and Alternate Number 1 for the amount of \$144,046.14 for a total of \$200,456.14. Additionally requesting that Ash Street be approved using the same cost figures as 6th Street to utilize the remaining funds.



Hanson Professional Services
789 E. Washington St.
Brownsville, Texas 78520
(956) 541-1155
Fax (615) 871-8013
www.hanson-inc.com

1.5.2.a

November 8, 2018

Mark Milum
200 N. Brazil St.
Los Fresnos, Texas 78566

RE: 2017-2018 CDBG Los Fresnos Drainage Improvements TCDP No. 7217269

Mr. Milum:

Bids were opened for the above referenced project on Tuesday November 6, 2018 at 3:00 pm, at Los Fresnos City Hall. Ten (10) bids were received, opened and read aloud to the public. G & T Paving Co., located in Brownsville, Texas submitted the apparent low bid with a base bid amount of \$56,410.00. We have reviewed the bids for accuracy and find that all the documentation is in order. Attached for your review and record is a copy of the project bid tabulation which summarizes the bids received from each contractor.

Hanson Professional Services Inc. has reviewed the information submitted by all bidders and has verified the experience and references provided by the low bidder. It is our opinion that the low bid is fair and reasonable cost for the value of the work to be constructed, and that G & T Paving Co. is qualified to perform the required work.

Therefore, we hereby recommend award of the Contract to G & T Paving Co. in the amount of \$56,410.00 (Base Bid) + \$144,046.14(Additive No.1 and Alternate No.1). The construction budget for this project is \$254,000.00.

CDBG Construction Grant Funds	\$254,000.00
Base Bid (Drainage Improvements near Ash Street)	\$ 56,410.00
Additive No.1 (Drainage Improvements on 6 th Street) +	
Alternate No.1 (Street Improvements on 6 th Street)	<u>\$144,046.14</u>
Total Contract	\$200,456.14
Remaining Grant Funds	\$ 53,543.86

Should you have any questions or require any additional information, please do not hesitate to contact us.

Sincerely,

Hanson Professional Services Inc.

Anna M. Aldridge, P.E.
Senior Project Manager

I:\18jobs\18L0018\Admin\02-Task Management\1000 Design\Bidding\Award Recommendation\Award Recommendation RV1.doc

TABE Firm 13553 ■ TBPE Firm 417 ■ TBPG Firm 50017 ■ TBPLS Firm 100395-00

Attachment: Award Recommendation Letter 2017 2018 CDBG 7217269 (2861 : Award bid TXCDBG 7217269)

Table containing bid tabulation data for project 18L0018 CDBG Los Fresnos Drainage Improvements TCDP No. 7217269. Includes sections for BID TABULATION, BIDDERS, ADDITIVE NO. 1, ALTERNATE A1.1, ALTERNATE A1.2, and ADDITIVE NO. 2.

Attachment: bid tab CDBG 7217269 (2861) : Award bid TXCDBG 7217269

City Council
200 North Brazil
Los Fresnos, TX 78566

Meeting: 12/11/18 06:00 PM
Department: City Secretary
Category: Agreement
Prepared By: Jacqueline Moya
Initiator: Jacqueline Moya
Sponsors:

SCHEDULED

ACTION ITEM (ID # 2863)

DOC ID: 2863 A

Consideration and ACTION to approve or reject an Inter local Agreement with Bayview Irrigation District.

Attached is an agreement with Bayview Irrigation District that will allow us to utilize their canal for drainage during major flood events. This would move water in areas that flood through the canal to the east to a drainage ditch owned by Cameron County Drainage District #1. The Drainage District likes that idea as it helps them as well. Bayview Irrigation District is still wanting to get their canal placed underground. If or when this occurs, the city will be allowed to install a drain pipe underground as well to pipe water to the east utilizing their right-of-way for the canal. Additionally, the City will be able to utilize the top portion of the right-of-way for hike and bike trails. Other benefits will be water loss savings for them and a better and easier maintained right-of-way. As a grant is received the City would be responsible for the match for the work on the area inside the City limits. This would be done in increments that the City can budget for and will come to the Council each time for approval. The first section would be from Highway 100 at O'Reilly Auto Parts going north to at least the turn to go east with a total cost estimate of \$300,000. For that project the 50% match would be \$150,000. For the right to use the canal and right-of-way they are asking the City to pay a 1 time fee of \$9,000.

I recommend approval of the interlocal agreement with Bayview Irrigation District.

**INTERLOCAL COOPERATION CONTRACT BETWEEN
BAYVIEW IRRIGATION DISTRICT NO. 11
AND
CITY OF LOS FRESNOS

CONNECTING CANAL PIPING PROJECT**

DATE: October 24, 2018

This contract is made pursuant to TEXAS GOVERNMENT CODE Chapter 791, by and between:

BAYVIEW IRRIGATION DISTRICT NO. 11, having its office at 110 South San Roman Road, Bayview, Texas [mailing address, 110 South San Roman Road, Los Fresnos, Texas 78566] (hereinafter referred to as "IRRIGATION DISTRICT"), acting by and through its Board of Directors, and

CITY OF LOS FRESNOS, having its office at 200 North Brazil, Los Fresnos, Texas 78566 (hereinafter referred to as "CITY"), acting by and through its City Council.

1. SITUATION.

- 1.1 IRRIGATION DISTRICT wants to pipe its "Connecting Canal," an open irrigation canal, that runs from a point on Highway 100 in the City of Los Fresnos to its Main Canal near Bayview, Texas, a distance of approximately 7.4 miles. *See* Map 2.
- 1.2 Approximately 1.4 miles of the Connecting Canal is within the limits of CITY. CITY's extra-territorial jurisdiction extends one (1) mile beyond its limit. *See* Map 3.
- 1.3 IRRIGATION DISTRICT is going to apply for a grant to pay for preparation of the plans and the piping. It is likely the grant will require a local match of funds.
- 1.4 IRRIGATION DISTRICT has engaged Patty Alexander to prepare the grant application; her fee is \$4,000.00.
- 1.5 IRRIGATION DISTRICT has engaged Moore Engineering to provide the engineering information, cost estimates, and other technical data required for the grant application; its fee is \$5,000.00. That is, this fee is only for the grant application, and does not include the preparation of construction plans or work done on the project after the award of the grant. If the grant is awarded, Moore Engineering shall prepare the plans and serve as engineer for the project.
- 1.6 If the Connecting Canal is piped, the CITY wants to:
 - (a) Use the surface of the Connecting Canal right-of-way for a hike and bike trail and other recreational purposes. At a minimum, CITY wants to use that part of the right-of-way within the limits of CITY. If possible, CITY wants to use all or part of the right-of-way within its ETJ. If legally permissible, CITY, most likely in partnership with other entities, may want to use all or part of the right-of-way that is beyond the limit of its ETJ for a hike and bike trail and other recreational purposes.
 - (b) Provide drainage relief for that part of CITY north of the Connecting Canal by installing an underground drain pipeline in the Connecting Canal right-of-way to transport storm water to one of Cameron County Drainage District No. 1's drains.
- 1.7 Conceptually, during significant rain events, when IRRIGATION DISTRICT is not transporting water to its customers, the CONNECTING CANAL can accept storm water. Until the CONNECTING CANAL is piped:
 - (a) CITY wants to use the CONNECTING CANAL as a drain to transport storm water from one or more points east of the northwest corner of Block 170,

Fresnos Land & Irrigation Company Subdivision, to one of Cameron County Drainage District No. 1's drains east of Arroyo Boulevard/F.M. 1847, also known as Paredes Line Road:

- (i) At the most westerly point the storm water enters the CONNECTING CANAL, a gate shall be installed in the CONNECTING CANAL to prevent the back flow of storm water.
 - (ii) At each point the storm water enters the Canal, there must be a gate that must remain closed until IRRIGATION DISTRICT authorizes the opening of the gate(s).
 - (iii) At the point the storm water shall be discharged into Cameron County Drainage District No. 1's drain, hereinafter referred to as "diversion point", a gate shall be installed in the CONNECTING CANAL to prevent storm water from flowing past the diversion point. Put another way, the diversion structure must be designed so that (a) when IRRIGATION DISTRICT is using the CONNECTING CANAL, the flow of water in the canal is unimpeded and no irrigation water flows into Cameron County Drainage District No. 1's drain.
 - (iv) At the diversion point, a gate or other control structure shall be installed to prevent water from being discharged from the CONNECTING CANAL until the IRRIGATION DISTRICT authorizes the release of water from the CONNECTING CANAL.
- (b) Depending on the quality of the storm water and/or the capacity of IRRIGATION DISTRICT's system to accept the storm water, IRRIGATION DISTRICT may be willing to accept part or all of the storm water.
- 1.8 CITY is willing to pay (a) the cost of preparation of the plans for piping all of the Canal that is not covered by the grant, and (b) the cost of piping the canal in the segment designated by CITY that is not covered by the grant, provided that depending on the amount of the grant allocated to the cost of piping the canal, the piping of the CANAL within the segment designated by City may have to be done in phases, in which case, IRRIGATION DISTRICT shall apply for additional grants.

2. AGREEMENT.

- 2.1 At the time this Interlocal Contract is signed, CITY shall pay to IRRIGATION DISTRICT the sum of \$9,000.00, the payment of which is hereby acknowledged by IRRIGATION DISTRICT.
- 2.2 CITY, at CITY's sole expense, shall determine the feasibility of using a segment of the CONNECTING CANAL as a drain as discussed in Paragraph 1.7. If CITY determines that using a segment of the CONNECTING CANAL as a drain is feasible:
- (a) CITY, at CITY's sole expense, (i) shall prepare the plans for all necessary gates and other facilities and structures discussed in Paragraph 1.7, and (ii) construct the gates and other facilities.
 - (b) No construction shall commence until IRRIGATION DISTRICT's Board of Directors has approved the plans for the inlet and diversion facilities in writing.
 - (c) Until determined by IRRIGATION DISTRICT's Manager:
 - (i) the gates in the CONNECTING CANAL shall remain open, and
 - (ii) the gates of the inlet(s) and outlet shall remain closed.
 That is, either after, or simultaneously with, the closing of the gates in the CONNECTING CANAL, the gate(s) in the inlet(s) and outlet can be opened. Provided, if IRRIGATION DISTRICT's Manager determines that IRRIGATION DISTRICT will accept part or all of the storm water, the gate in the CONNECTING CANAL at the diversion point shall remain fully open or shall be partially closed as determined by the Manager. At the conclusion of the storm event, the gates will be returned to the pre-storm event status. The managers of IRRIGATION DISTRICT and CITY shall be responsible for establishing the protocol regarding the opening and closing of the gates, including who opens and closes the gates.

- 2.3 CITY shall designate the segment of the CONNECTING CANAL that it wants piped, and CITY shall pay the cost of piping the segment designated that is not paid/covered by the grant. As discussed in Paragraph 1.8, the piping of the segment designated by CITY can be done in phases.
- 2.4 In consideration for CITY's payment of the costs required by Paragraphs 2.1 and 2.3, above, as each phase of piping is completed in the segment designated by CITY, IRRIGATION DISTRICT shall:
 - (a) convey to CITY the right to use the surface of the piped segment for a hike and bike trail and other recreational purposes:
 - (i) "as is" (there may be encroachments of fences and other improvements); and
 - (ii) subject to IRRIGATION DISTRICT's superior right to repair, and if necessary, replace the pipeline.
 - (b) convey to City an easement for the underground drain pipe discussed in Paragraph 1.6(b), above, as constructed.
- 2.5 This document constitutes the entire agreement between IRRIGATION DISTRICT and CITY and no representations, warranties, express or implied, inducement, promises, and agreements, oral or otherwise, between the parties not embodied herein, or in a duly adopted amendment hereto or Interlocal Cooperation Contract between IRRIGATION DISTRICT and CITY shall be of any force or effect.

IN WITNESS WHEREOF, the undersigned have executed this AGREEMENT in duplicate originals.

BAYVIEW IRRIGATION DISTRICT NO. 11

By: _____
Ernesto Martinez, President

CITY OF LOS FRESNOS

By: _____
Polo Narvaez, Mayor

ATTEST:

Jacqueline Moya, City Secretary

Attachment: BAYVIEW IRRIGATION DISTRICT AGREEMENT (2863 : Bayview Irrigation District No.11-Agreement)

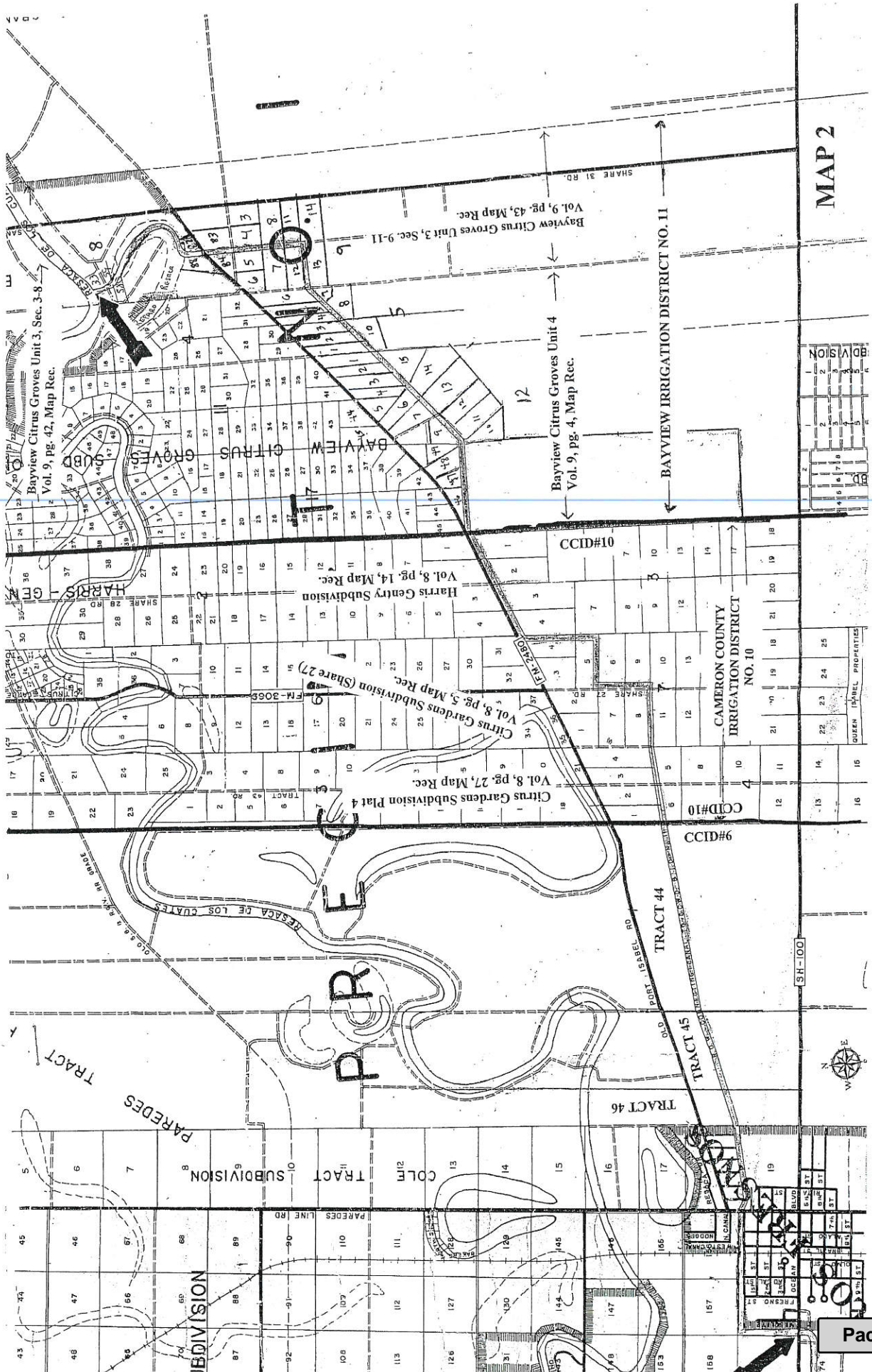

MAP 2

Attachment: BAYVIEW IRRIGATION DISTRICT AGREEMENT (2863 : Bayview Irrigation District No.11-Agreement)

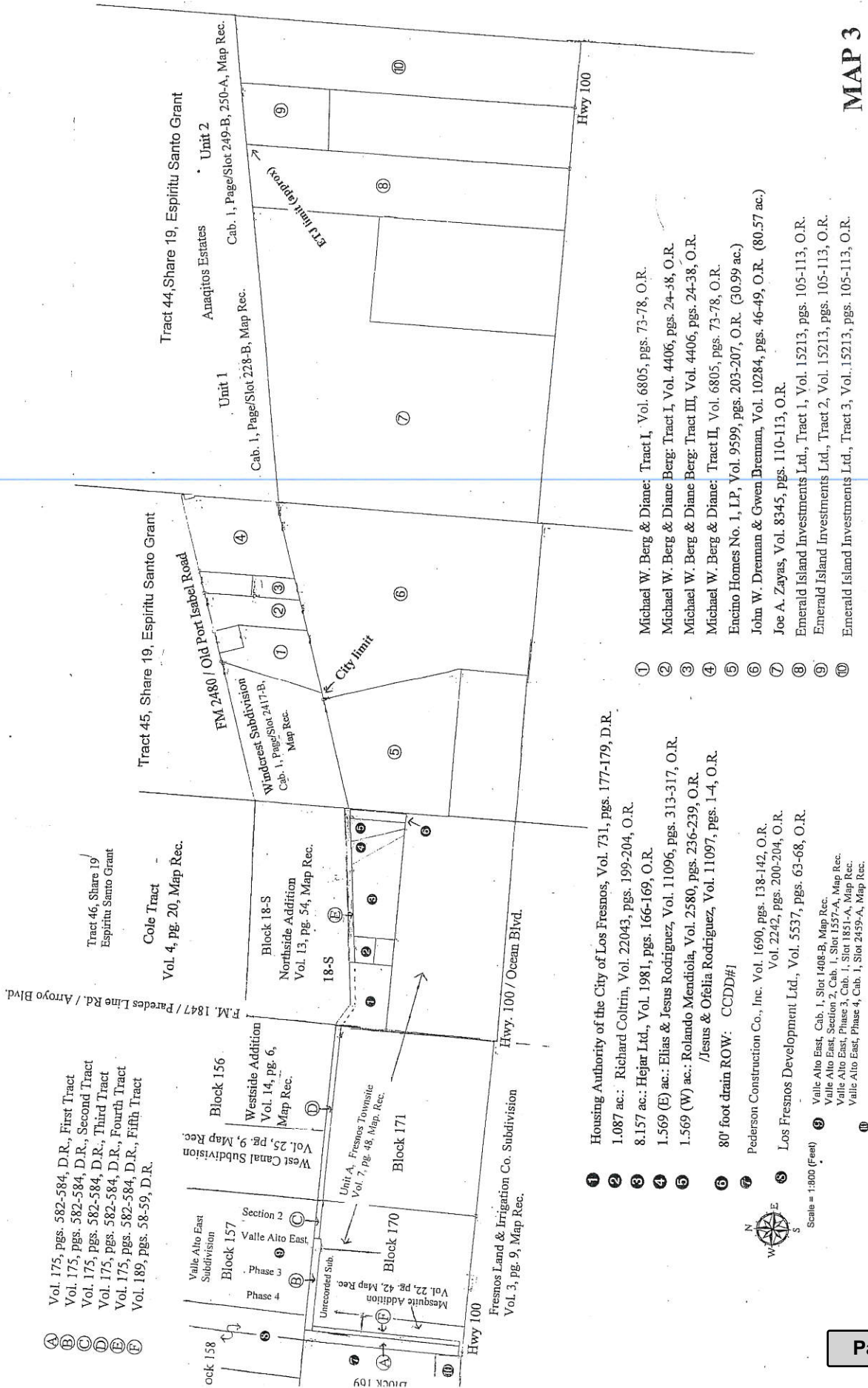

- ① Housing Authority of the City of Los Fresnos, Vol. 731, pgs. 177-179, D.R.
- ② 1.087 ac.: Richard Coltrin, Vol. 22043, pgs. 199-204, O.R.
- ③ 8.157 ac.: Hejar Ltd., Vol. 1981, pgs. 166-169, O.R.
- ④ 1.569 (E) ac.: Elias & Jesus Rodriguez, Vol. 11096, pgs. 313-317, O.R.
- ⑤ 1.569 (W) ac.: Rolando Mendiolia, Vol. 2580, pgs. 236-239, O.R.
/Jesus & Ofelia Rodriguez, Vol. 11097, pgs. 1-4, O.R.
- ⑥ 80' foot drain ROW: CCDD#1
- ⑦ Peterson Construction Co., Inc. Vol. 1690, pgs. 138-142, O.R.
Vol. 2242, pgs. 200-204, O.R.
- ⑧ Los Fresnos Development Ltd., Vol. 5537, pgs. 63-68, O.R.
- ⑨ Valle Alto East, Cdb. 1, Slot 1408-B, Map Rec.
Valle Alto East, Section 2, Cdb. 1, Slot 1537-A, Map Rec.
Valle Alto East, Phase 3, Cdb. 1, Slot 1851-A, Map Rec.
Valle Alto East, Phase 4, Cdb. 1, Slot 2459-A, Map Rec.
- ⑩

- ① Michael W. Berg & Diane: Tract I, Vol. 6805, pgs. 73-78, O.R.
- ② Michael W. Berg & Diane Berg: Tract I, Vol. 4406, pgs. 24-38, O.R.
- ③ Michael W. Berg & Diane Berg: Tract III, Vol. 4406, pgs. 24-38, O.R.
- ④ Michael W. Berg & Diane: Tract II, Vol. 6805, pgs. 73-78, O.R.
- ⑤ Encino Homes No. 1, LP, Vol. 9599, pgs. 203-207, O.R. (30.99 ac.)
- ⑥ John W. Drenman & Gwen Drenman, Vol. 10284, pgs. 46-49, O.R. (80.57 ac.)
- ⑦ Joe A. Zayas, Vol. 8345, pgs. 110-113, O.R.
- ⑧ Emerald Island Investments Ltd., Tract 1, Vol. 15213, pgs. 105-113, O.R.
- ⑨ Emerald Island Investments Ltd., Tract 2, Vol. 15213, pgs. 105-113, O.R.
- ⑩ Emerald Island Investments Ltd., Tract 3, Vol. 15213, pgs. 105-113, O.R.

MAP 3

City Council
200 North Brazil
Los Fresnos, TX 78566

Meeting: 12/11/18 06:00 PM
Department: City Secretary
Category: Policy
Prepared By: Jacqueline Moya
Initiator: Jacqueline Moya
Sponsors:
DOC ID: 2859 A

SCHEDULED

ACTION ITEM (ID # 2859)

Consideration and ACTION to approve designating December 31st as a holiday.

Depending on the day the 31st of December or New Years Eve falls on, due to New Years Eve plans with family for our employees becomes difficult if we work until 5:00. It was suggested that we offer our employees New Years Eve off giving them ample time to spend with family and friends. Lots of businesses already do that and there never pressing items that must be handled during that time of the year due to the Holiday Season. From time to time we have allowed employees to leave early but it has never been something that is official. I thought it best if a decision was made one way or the other.

he/she should report to a certain military facility for duty, physical exam, etc., then the employee will be paid under his/her own personal sick, annual, or compensatory time leave. If granted military leave, this leave of absence shall be in addition to any other form of leave with pay to which the employee is normally entitled and shall not exceed fifteen (15) working days or days for which the employee would normally receive pay in any one federal fiscal year.

4.11 Other Forms of Leave

- A. Attendance of conferences, schools, etc., on recommendation of Department Heads or on his own initiative, the City Manager may grant leave with pay, together with necessary travel and expense allowance, if deemed proper, in order to permit employees to attend conferences, schools, and similar events designed to improve their efficiency and considered as being beneficial to the interest of the City. Attendance of conferences or schools is to be limited to the financial provisions of each department for such training. (See Section 3.05 for travel guidelines).
- B. Jury and Court Service – An employee who is legally summoned to serve on a jury or in court trials shall be permitted absence with pay by his/her Department Head for such duty.

4.12 Rest Breaks

Rest breaks will be fifteen (15) minutes duration, one in the morning and one in the afternoon. Employees will arrange their rest breaks in accordance with department procedures to not interfere with City business. Employees will be entitled to this privilege as long as they do not abuse it. The City retains the right to require employees to work through breaks under special or emergency conditions.

4.13 Holidays

The City officially declares and designates the following holidays to be observed with pay by regular full-time employees, and subject to the provisions and limitations hereinafter set forth:

New Years Day	January 1 st
Presidents Day	Third Monday in February
Good Friday	Friday before Easter
Memorial Day	Last Monday in May
Independence Day	July 4 th
Labor Day	First Monday in September
Columbus Day	Second Monday in October
Veterans Day	November 11 th
Thanksgiving Day	Fourth Thursday in November
Day after Thanksgiving Day	Fourth Friday in November
Christmas Eve	December 24 th
Christmas Day	December 25 th

Attachment: HOLIDAYS (2859 : December 31st 2018)

City Council
200 North Brazil
Los Fresnos, TX 78566

Meeting: 12/11/18 06:00 PM
Department: City Secretary
Category: Agreement
Prepared By: Jacqueline Moya
Initiator: Jacqueline Moya
Sponsors:

SCHEDULED

ACTION ITEM (ID # 2854)

DOC ID: 2854 A

Consideration and ACTION for the Mayor to support and participate in the HEB 2019 Step Up Community Challenge.

The community health program is promoting this challenge in hopes of getting more folks involved in healthy living. Points are received when folks participate, eat well and exercise. Points are also received for the Mayor's support. We need this as well as a photo of the Mayor with the pledge.

I recommend approval.

MAYOR PLEDGE

In Support of the IT'S TIME TEXAS Community Challenge,

I, Mayor _____, of _____ Texas

PLEDGE TO:

- Kick off the IT'S TIME TEXAS Community Challenge by declaring my support and encouraging our constituents to participate

To Earn Challenge Points For Our Community, I Will:

- E-mail a photo of myself holding the Pledge to mayorpledge@itstimetexas.org to be featured on the Challenge website (Required, 10,000 points)
- Ask City Council members to sign and upload a photo of the group holding the Pledge on the Challenge site (2,500 points)
- Create and upload a short video that promotes the IT'S TIME TEXAS Community Challenge and calls on another Texas Mayor to compete (15,000 points)
- Establish or strengthen a Community Health Collaborative in my community (20,000 points)
- Host and speak at an IT'S TIME TEXAS-sanctioned event in my community that promotes healthy living and the Community Challenge (5,000 points)

I recognize that a healthy community is more united, more productive, and more prosperous. As a result, I am committed to the health of my community and pledge to make our community a model for others to follow.

MY CITY IS UP TO THE CHALLENGE!

Mayor's Signature:

Signed _____ Date _____

Let your community know you've signed your pledge by taking a photo holding your signed pledge and posting it to social media with the hashtag #CommunityChallenge!



Association of Texas Professional Educators is a strategic partner of IT'S TIME TEXAS and the Community Challenge. www.atpe.org

This institution is an equal opportunity provider. This material was funded by USDA's Supplemental Nutrition Assistance Program -- SNAP. To receive assistance purchasing healthy foods, sign up for SNAP benefits at yourtexasbenefits.com

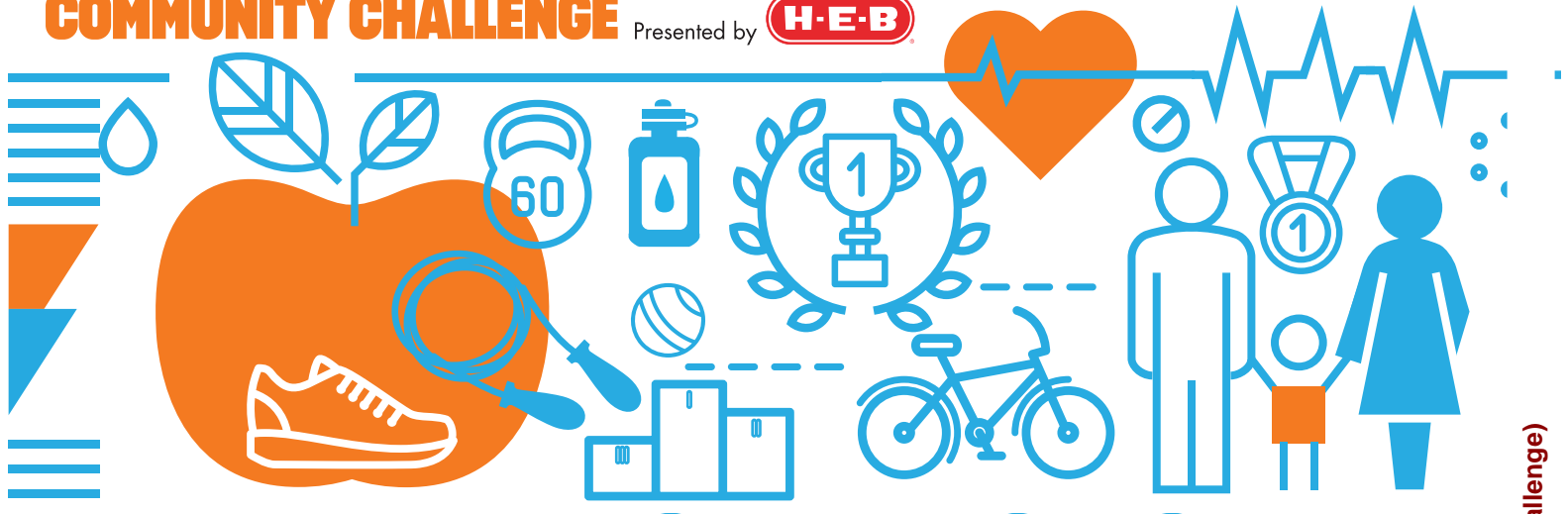

TEXAS MAYORS STEP UP TO THE 2019 IT'S TIME TEXAS COMMUNITY CHALLENGE

JANUARY 7 - MARCH 3

2019

A HEALTHIER COMMUNITY STARTS WITH YOU!

Join the IT'S TIME TEXAS Community Challenge and demonstrate your commitment to healthy living. Mayors, residents, schools, businesses, and organizations across the state earn points for their cities and towns simply by making healthier choices. The winning community in each size category will receive funds to put toward future community health efforts!

HOW YOU CAN EARN POINTS FOR YOUR COMMUNITY:

- » **5,000 POINTS - HOST AN IT'S TIME TEXAS-SANCTIONED EVENT**
and speak to your residents about the importance of healthy living using the script provided on the Challenge website.
- » **10,000 POINTS - SIGN THE MAYOR PLEDGE!**
You must sign this pledge for your community to be eligible to win the Community Challenge. There is also a pledge available for your City Council members to sign.
- » **15,000 POINTS -FILM A CHALLENGE VIDEO**
encouraging your residents to get involved and challenging a neighboring community to compete with you!
- » **20,000 POINTS - FORM OR STRENGTHEN A CITYWIDE HEALTH COLLABORATIVE**
Requirements are listed on the Challenge website.

HOW IT WORKS

REGISTER OCT 8
@ittcommunitychallenge.co
to earn bonus points and rec
all kinds of fun tips & resourc

THEN STARTING JANUAR

UPLOAD PHOTOS
every day of healthy eatin
exercise, and physical acti

SUBMIT ACTIVITY
through the fitness tacker
on the website.

EARN POINTS
for your community and
encourage others to regis

Attachment: Mayor How It Works (2854 : HEB 2019 Step Up Community Challenge)

REGISTER AT WWW.ITTCOMMUNITYCHALLENGE.COM



This institution is an equal opportunity provider. This material was funded by USDA's Supplemental Nutrition Assistance Program-SNAP. To receive assistance purchasing healthy foods, sign up for SNAP benefits at yourtexasbenefits.com.

City Council
200 North Brazil
Los Fresnos, TX 78566

Meeting: 12/11/18 06:00 PM
Department: City Secretary
Category: Agreement
Prepared By: Jacqueline Moya
Initiator: Jacqueline Moya
Sponsors:

SCHEDULED

ACTION ITEM (ID # 2857)

DOC ID: 2857 A

Consideration and ACTION for the City Council members to support and participate in the HEB 2019 Step Up Community Challenge.

The community health program is promoting this challenge in hopes of getting more folks involved in healthy living. Points are received when folks participate, eat well and exercise. Points are also received for the Council's support. We need this along with a photo of the Council and the pledge.

I recommend approval.

CITY COUNCIL'S PLEDGE

In Support of the IT'S TIME TEXAS Community Challenge,

We, the City Council of _____, Texas

PLEDGE TO:

Kick off the IT'S TIME TEXAS Community Challenge by declaring our support and encouraging our constituents to participate!

To Earn Challenge Points For Our Community, We Will:

- » Declare our support by signing the pledge and uploading a picture of the group holding the pledge to the Challenge site (For 2,500 pts.)
- » Encourage our Mayor to sign the Community Challenge Pledge if it hasn't been submitted.
- » Establish or strengthen a Mayor's Health and Fitness Council or Citywide Health Collaborative (Optional, for 20,000 points)

We recognize that a healthy community is more united, more productive, and more prosperous. As a result, we are committed to the health of my community and pledge to make our community a model for others to follow.

OUR CITY IS UP TO THE CHALLENGE!

Council Members Signatures:

Signed _____	Date _____
Signed _____	Date _____
Signed _____	Date _____
Signed _____	Date _____



Association of Texas Professional Educators is a strategic partner of IT'S TIME TEXAS and the Community Challenge. www.atpe.org

This institution is an equal opportunity provider. This material was funded by USDA's Supplemental Nutrition Assistance Program -- SNAP To receive assistance purchasing healthy foods, sign up for SNAP benefits at yourtexasbenefits.com.

Attachment: Pledge City Councils 2019_CC (2857 : HEB 2019 Step Up Community Challenge)

City Council
200 North Brazil
Los Fresnos, TX 78566

Meeting: 12/11/18 06:00 PM
Department: City Secretary
Category: Report
Prepared By: Jacqueline Moya
Initiator: Jacqueline Moya
Sponsors:

SCHEDULED

ACTION ITEM (ID # 2844)

DOC ID: 2844 A

City Manager Report A. Wastewater Plant Update B. Water Plant Update C. Water & Wastewater Engineering Study D. Whipple Road Wastewater Extension E. Nature Park F. Hike & Bike Trails G. CDBG 2017-2018 Grant H. Henderson Road Project I. City Hall Project J. Building Inspections K. Underground Canal L. Dog Park M. Development and Annexation Plans N. Update Planning & Zoning Ordinance O. Economic Development

A. Wastewater Plant Update - Construction is ongoing for the sludge project. The plans and documents were sent to TWDB on December the 5th for the chlorine contact basin. The plans and documents will be sent to TWDB on December 12th for the headworks project. Once these are approve by TWDB we can advertise for bids. In a perfect world we hope to have bids to approve by the Council by February or at the latest March.

B. Water Plant Update - We have approval from TCEQ and TWDB to proceed with working to get the upgrades done on the water plant and distribution lines. Pablo will be working with our financial advisors, bond council and TWDB to apply for this funding. It is included in the study under C.

C. Water & Wastewater Engineering Study - The water & wastewater portions have been approved by TCEQ and TWDB. The Council approved asking for about \$1,600,000 to fix 3 lift stations, run sewer service to the new annexed areas on West Highway 100, replace some old manholes and replace some old sewer lines. There are no grants available for this but we can probably get a low interest loan. The intent will be to do this with no increase in sewer rates. The amounts we can save on repairs can go towards the loan payment. The Council approved the upgrades needed at the water plant and water system for \$3,700,000. We will look for funding for these 2 projects.

D. Whipple Road Wastewater Extension - Hanson Professional Services has the documents ready for us to advertise, bid, award contract and begin construction. The City has to acquire the easements prior to that. I have not had time to work on these easements. Hopefully that can be done soon.

E. Nature Park - Work is done for phase 2 except for the some signage that we are waiting to be completed. It really looks great. If you haven't gone by to see you should. I'd be glad to go with you. We are working on phase 3 so we can expend the rest of the funds from TPW which is about \$171,000.

F. Hike & Bike Trails - Halff Associates is working on the final design, the timeline and a construction estimate. We are still waiting on TxDOT to get final approval as they have discovered 2 plants that are on an extinct list so we will have to deal with that. Due to this delay Valley Baptist Legacy Foundation has requested that we return the unused funds. We have done that and once the project is cleared environmentally and we bid the project, we can start drawing funds as work is done. This is not a problem as most grants work that way (work is done and they release funds accordingly).

G. CDBG 2017-2018 Grant - This is to upgrade drainage on Ash Street, Ebony Street and Pecan Street along the canal as well as on East Sixth Street and Ebano Street. It also includes placing the drainage underground along Olmo Street from Eight Street to Tenth Street if funding is available. Hanson Professional Services was selected by the Council to do the engineering work. Bids will hopefully approved by Council at this meeting.

H. Henderson Road Project - Ambiotec provided me with exhibits so I can utilize them to meet with each property owner to work out an agreement with them if possible. I have not had time to work on them due to flooding and other projects as well as working on budget for next year. The environmental clearance has been approved by all agencies. Unfortunately some of the requirements may cause the project cost to increase. I asked Ambiotec if they could assist in acquiring the property for us but It will cost \$2,000 per property which would be over \$20,000. I will find time to get it done.

I. City Hall Project - Work is continuing.

J. Building Inspections - We are still working out the details to hire a candidate to handle inspections except the plumbing. It requires very specialized certifications.

K. Underground Canal - Bayview Irrigation District is interested in getting a survey done so estimated can be done for potential grants. They have now mentioned that they could possible allow us to use the canal to move the drainage water to the east to another drainage ditch. I met with the drainage district and they are meeting with their engineer to see if that will work for them. They feel it will be greatly beneficial and relieve so much water in the areas more prone to flood. Bayview Irrigation District also said they can allow us to place drainage in their ROW once the canal is placed underground. If they allow us to do that they would like us to pay \$9,000 for the use. The agreement will be on this agenda.

L. Dog Park - Wal-Mart is interested in moving this project forward. I called there real estate folks again but have not made any progress.

M. Development & Annexation Plans - Will work on this later in the year but annexation costs a lot of money that we don't have so I do not recommend any annexation plans at this time.

N. Update Planning & Zoning Ordinance - I am reaching out to firms that specialize in this work to assist us. Will share information when I get some data.

O. Economic Development - Retail Coach is out promoting the city to different retailers. The have had some good discussions with several potential retailers but nothing firm to report.

City Council
200 North Brazil
Los Fresnos, TX 78566

Meeting: 12/11/18 06:00 PM
Department: City Secretary
Category: Report
Prepared By: Jacqueline Moya
Initiator: Jacqueline Moya
Sponsors:
DOC ID: 2846

SCHEDULED

ACTION ITEM (ID # 2846)

Financial Report 1. Monthly 2. Year to Date 3. Sales Tax

Call with questions.

I recommend approval.

CHECKLIST FOR				NOVEMBER 2018
GENERAL FUND				
CK#	VENDOR NAME	Inv.Date	Amount	Description
223	CITY OF L.F. PAYROLL ACCT	11/01/18	\$ 69,448.65	DUE TO PAYROLL #2 11/2/18
232	CITY OF L.F. PAYROLL ACCT	11/15/18	\$ 68,315.24	DUE TO PAYROLL #3 11/16/18
235	CITY OF L.F. PAYROLL ACCT	11/29/18	\$ 67,014.25	DUE TO PAYROLL #4 11/30/18
32840	LIZBET CHAPA ZUNIGA	08/30/18	VOID	VOIDED CHECK-TO BE REISSUED-RENTAL DEPOSIT REFUN
32893	CAMERON COUNTY TAX ASSESSOR	09/14/18	VOID	VOIDED CHECK-INCORRECT AMOUNT-LICENSE RENEWALS-CI
33101	JAVIER GARCIA	11/02/18	\$ 7.50	REIMBURSE-LICENSE RENEWAL-STREET SWEEPER
33102	GALL'S	11/06/18	\$ 456.00	BULLET PROOF VEST-POLICE DEPT
33103	ANDREW LARA	11/09/18	\$ 50.00	RENTAL DEPOSIT REFUND-LF MEMORIAL PARK 10/27/18
33104	KEVIN MOKHABERY	11/09/18	\$ 113.90	OVER PAYMENT-E0015364
33105	LARRY BROWN	11/09/18	\$ 1.00	OVER PAYMENT-116390
33106	A-1 AUTO GLASS	09/28/18	\$ 275.00	FRONT WINDSHIELDS-F-52/F-174 PD UNITS
33107	A&M AUTOMOTIVE	VARIOUS	\$ 686.06	REPAIR PD UNIT F-61 BALL JOINT ASSEMBLY/INSPECTION-F
33108	ALICIA LERMA	11/02/18	\$ 500.00	POWER WASH ALAMO WAREHOUSE BUILDING
33109	ALLIED WASTE SERVICES	10/31/18	\$ 53,699.89	SOLID WASTE & BRUSH COLLECTION-RESIDENTIAL/COMME
33110	AMIGO POWER EQUIPMENT	09/30/18	\$ 14,562.00	2 POLARIS SPORTMANS-PD UNITS
33111	ARCHER BUSINESS SYSTEMS	10/30/18	\$ 692.33	COPIER METER READING-CITY HALL-COLOR COPIES-PD/HE
33112	CAMERON COUNTY TAX	09/11/18	\$ 7.50	LICENSE RENEWAL-RD-162
33113	CC DISTRIBUTORS	11/01/18	\$ 71.31	CLEANING SUPPLIES-CITY BUILDINGS
33114	CCID #6	10/22/18	\$ 300.00	MOWING-OLMO STREET DRAINAGE DITCH
33115	CHOCO'S TIRE SHOP	10/23/18	\$ 65.00	FLAT REPAIR ON JOHN DEERE TRACTOR RD-161
33116	CINTAS	10/29/18	\$ 299.25	MEDICAL SUPPLIES-CITY HALL/POLICE DEPT/COMM.CENTE
33117	CITY OF LOS FRESNOS	10/20/18	\$ 2,118.62	WATER SERVICE-CH/PD/COURT/FIRE DEPT/PARKS/POOL/TF
33118	CITY OF LOS FRESNOS	10/21/18	VOID	VOIDED CHECK-CONTINUED
33119	DAHILL INDUSTRIES	10/31/18	\$ 30.31	COPIER MAINTENANCE-METER READING-LIBRARY
33120	DANIEL MARCHAN	10/11/18	\$ 6.64	REIMBURSE-PRICE DIFFERENCE-HOTEL-TAPEIT CONFERE
33121	DELTA SPECIALTIES SUPPLY	10/22/18	\$ 277.43	STREET SIGNS-NO PARKING/RODEO DR/ E. OCEAN/SIGN BR
33122	DEMCO	10/29/18	\$ 194.69	LIBRARY BOOK SUPPLIES-BOOK JACKETS/SPINE LABELS
33123	DIAMOND EIGHT INDUSTRIES	10/29/18	\$ 2,000.00	CLEAN EROSION FROM NATURE PARK TRAILS/RECONDITIO
33124	DIRECT ENERGY	VARIOUS	\$ 10,281.59	ELEC-STREETS/CITY HALL/PD/COURT/PARKS/B&G CLUB
33125	DIRECT ENERGY	VARIOUS	VOID	VOIDED CHECK-CONTINUED
33126	ELECTRONIC TRANSACTION SYS	10/29/18	\$ 424.22	CREDIT/DEBIT CARD READER FOR LIBRARY
33127	ENRIQUE JUAREZ	10/31/18	\$ 3,500.00	OCT 2018-ATTORNEY FEES
33128	FUELMAN	VARIOUS	\$ 1,903.74	FUEL FOR ENVIRONMENTAL/PD/STREET DEPT VEHICLES
33129	GALL'S	09/30/18	\$ 400.00	TACTICAL BOOTS FOR POLICE DEPT
33130	GENE DANIELS	11/01/18	\$ 1,850.00	NOV 2018-JUDGE/PHONE STIPEND
33131	GERONIMO SHELDON	11/01/18	\$ 451.00	NOV 2018-FIRE MARSHAL
33132	GLOBLFONE	11/06/18	\$ 200.00	IRIDIUM PHONE SERVICE-10/18-11/18
33133	GRANICUS	10/30/18	\$ 331.80	AGENDA/MINUTE-IQM2 SUBSCRIPTION-OCT 2018
33134	HECTOR'S MUFFLER	VARIOUS	\$ 318.04	INSTALL MOWER DECK BELT/FUEL FILTER REPLACEMENT-
33135	HERNANDEZ INSTALLATIONS	10/26/18	\$ 450.00	INSTALLATION OF LIGHTS ON PD POLARIS ATV'S
33136	INDUSTRIAL DISPOSAL	10/25/18	\$ 220.44	STREET SWEEPER-BLAST ORFICE CURTAIN
33137	KETCH-ALL COMPANY	09/30/18	\$ 2,100.00	SUPPLIES FOR ANIMAL CONTROL-DOG/RACCOON TRAPS/SN
33138	INTERNATIONAL CODE COUNCIL	10/29/18	\$ 135.00	BUILDING CODES MEMBERSHIP-2018-2019
33139	LINEBARGER GOGGAN	11/09/18	\$ 7,398.71	AUG 2018-SEPT 2018- COLLECTION FEES
33140	LOS FRESNOS CHAMBER OF COM	11/01/18	\$ 2,850.00	NOV 2018-SERVICE AGREEMENT
33141	LOS FRESNOS NEWS	VARIOUS	\$ 1,115.00	ADS-HEALTH MATTERS/ELECTION NOTICE/BIDS CDBG/BUIL
33142	LUIS RAMOS	10/31/18	\$ 2,621.79	OCT 2018-CUSTOMER SERVICE INSPECTIONS
33143	MCDONALD'S	VARIOUS	\$ 60.00	AUG 2018/OCT 2018-PRISONER MEALS
33144	MCCOY'S BUILDING SUPPLY	11/07/18	\$ 245.85	NATURE PARK RAIN HARVESTING SYSTEM SUPPLIES
33145	MIGUEL ANGEL HERNANDEZ	08/24/18	\$ 55.00	LOT MOWING LOT IN VIOLATION OF CITY ORDINANCE
33146	NOVA HEALTHCARE	VARIOUS	\$ 306.23	PRE EMPLOYMENT SCREENS-MCGINNIS/RODRIGUEZ/SANC
33147	O'REILLY AUTO	10/05/18	\$ 32.79	AIR FILTERS-PD UNITS-F-52/F-53/F-65
33148	OFFICE OF THE ATTORNEY GE	11/05/18	\$ 510.00	OPEN GOVERNMENT CONFERENCE 12/45/12/5/18-J.MOYA/B.
33149	PEDERSON CONSTRUCTION	11/07/18	\$ 425.00	TRUCK LOAD OF LIMESTONE-STREET REPAIRS
33150	PETTY CASH	VARIOUS	\$ 59.14	WALMART-FRUIT-CITY HALL EMPLOYEES
33151	PURCHASE POWER	09/30/18	\$ 457.88	SEPT 2018-POSTAGE-COURT/PD/LIBRARY/ENVIRON/CH
33152	SAM'S	10/19/18	\$ 223.84	POLICE DEPT-CANDY FOR HALLOWEEN EVENTS/DRUG FREE
33153	SAN BENITO NEWS	10/12/18	\$ 150.00	AD-CONJUNTO FESTIVAL

33154	SANCHEZ TIRE SHOP	11/06/18	\$ 10.00	REPAIR FLATS ON 16' TRAILER
33155	SILSBEE FORD INC	09/30/18	\$ 70,790.00	2-2019-FORD F-150 FOR POLICE DEPT
33156	TACTICAL GEAR.COM	VARIOUS	\$ 947.67	UNIFORMS-CID/DISPATCH/COMMAND STAFF-POLICE DEPT
33157	TAPEIT	09/28/18	\$ 700.00	TAPEIT 2018-CONFERENCE REGISTRATION-D.MARCHAN/J.I
33158	TYLER TECHNOLOGIES	11/01/18	\$ 826.01	ANNUAL SOFTWARE MAINT-LINEBARGER/PRINTER PAPER
33159	VALLEY SOLVENT & CHEMICAL	11/01/18	\$ 739.50	6- DRUMS SODIUM HYPOCHLORITE-POOL
33160	WAL-MART	10/12/18	\$ 192.11	POLICE DEPT FLEET MAINTENANCE SUPPLIES
33161	ROBERT M CANO	11/09/18	\$ 955.00	PAINT/MATERIALS-PAINTING ALAMO WAREHOUSE
33162	JACQUELINE MOYA	11/13/18	\$ 197.53	REIMBURSE-CAR RENTAL-TMCCP SEMINAR-FRISCO, TX 1/1
33163	JACQUELINE MOYA	11/13/18	\$ 189.10	REIMBURSE-FLIGHT-TMCCP SEMINAR-FRISCO, TX 1/18/18
33164	VALLEY TROPHIES LLC	11/13/18	\$ 74.00	APPRICIATION PLAQUES-COUNCIL MEMBERS
33165	ANGIE LANDAVERDE	11/21/18	\$ 100.00	RENTAL DEPOSIT REFUND LF COMMUNITY CENTER 11/10/1
33166	ELIZA TORRES	11/21/18	\$ 140.00	OVER PAYMENT-E0018077
33167	SANDRA RIVERA	11/21/18	\$ 100.00	RENTAL DEPOSIT REFUND LF COMMUNITY CENTER 11/17/1
33168	A&M AUTOMOTIVE	09/30/18	\$ 7.00	STATE INSPECTION EV-151
33169	ALLIED WASTE SERVICES	10/31/18	\$ 391.09	30 YD ROLL OFF/PICK UP SERVICE 11/1-11/31/18
33170	AMAZON.COM	VARIOUS	\$ 566.21	SAFETY EQUIPMENT FOR ATV USE/MCCMP COURSE BOOK
33171	AT&T MOBILITY	11/01/18	\$ 1,230.72	MOBILE PHONE SERVICE-CITY/PD/COURT/EM/HEALTH/COD
33172	BIANCA RAMIREZ	11/16/18	\$ 125.00	PER DIEM FOR OPEN GOVERNMENT CONFERENCE-SAN M/
33173	CDC	11/21/18	\$ 31,669.44	TAX ALLOCATION END 11/6/18
33174	CDW GOVERNMENT	11/06/18	\$ 1,206.49	NETWORK SWITCHES
33175	CITY OF BROWNSVILLE	10/31/18	\$ 72.00	USE OF SANITARY LANDFILL
33176	DATA MANAGEMENT	11/12/18	\$ 753.32	TIME CLOCK SOFTWARE MAINTENANCE
33177	EDWARD'S PEST MANAGEMENT	11/08/18	\$ 136.00	PEST CONTROL-CH/PD/LIBRARY/ANIMAL SHELTER/TRAININ
33178	ESMERALDA MACIAS	11/15/18	\$ 25.00	CUSTOM CAKE-NEW CITY COUNCIL MEMBERS
33179	FOREMOST TELECOMMUNICAT	11/15/18	\$ 80.42	INTERNET SERVICE-LIBRARY 12/1-12/31/18
33180	FRED PRYOR SEMINARS	11/15/18	\$ 298.50	PRYOR PLUS MEMBERSHIP-R.RODRIGUEZ/D.RATLIFF/K.HO
33181	FUELMAN	11/04/18	\$ 978.57	FUEL FOR ENVIRONMENTAL/PD/STREET DEPT VEHICLES
33182	GRANICUS	11/01/18	\$ 331.80	AGENDA/MINUTE-IQM2 MONTHLY SUBSCRIPTION
33183	HECTOR'S MUFFLER	VARIOUS	\$ 282.52	REPAIRS-PD UNITS/OIL CHANGE/CHANGE SPARK PLUGS F-
33184	HUGHES NETWORK	11/04/18	\$ 112.41	SATELLITE INTERNET-EOC
33185	ISABEL JARAMILLO	11/21/18	\$ 100.00	RENTAL DEPOSIT REFUND-LF COMMUNITY CENTER 11/11/1
33186	JACQUELINE MOYA	11/16/18	\$ 125.00	PER DIEM FOR OPEN GOVERNMENT CONFERENCE-SAN M/
33187	JAVIN MORALES	11/21/18	\$ 100.00	RENTAL DEPOSIT REFUND LF COMMUNITY CENTER 11/18/1
33188	JOHN DEERE POWER PLAN	10/18/18	\$ 190.01	Z930 MOWER BLADES
33189	LA QUINTA	11/16/18	\$ 409.40	HOTEL-OPEN GOVERNMENT CONFERENCE-B.RAMIREZ/J.M
33190	LEXIS NEXIS RISK DATA	10/31/18	\$ 100.00	PEOPLE SEARCH PROGRAM
33191	LINEBARGER GOGGAN	11/21/18	\$ 3,113.40	OCT 2018-COLLECTION FEES
33192	LOS FRESNOS CHAMBER	11/12/18	\$ 1,500.00	2018-CHRISTMAS FEST/PARADE SPONSOR
33193	LOWER RGV DEVELOPMENT	11/14/18	\$ 19,995.00	FY 2019-OPERATIONS ROUTE 45
33194	MAX TORRES	11/21/18	\$ 326.00	CLEANING-PD/HEALTH/PARKS/STREET DEPT VEHICLES
33195	MEJIA & ROSE	11/05/18	\$ 2,500.00	METES & BOUNDS-VETERANS MEMORIAL DRIVE
33196	MOTOROLA SOLUTIONS	09/30/18	\$ 17,851.80	SERVICE AGREEMENT FOR RADIOS 2017/2018
33197	MUNICIPAL CODE CORP	11/05/18	\$ 275.00	ADMIN SUPPORT FEE 11/1-10/31/19
33198	O'REILLY AUTO	VARIOUS	\$ 210.84	OCT 2018-SUPPLIES FOR MAINT/REPLACEMENT TRAILER J,
33199	PETTY CASH	VARIOUS	\$ 104.05	WALMART-FRUIT-CITY EMPLOYEES/CELL PHONE CASE/CAI
33200	ROAD RESCUE	11/15/18	\$ 1,364.00	124 BAGS-ASPHALT PATCH-STREET REPAIRS
33201	SMARTCOM TELEPHONE	11/08/18	\$ 483.38	INTERNET SERVICE-CITY HALL/POLICE DEPT/COURT/PHON
33202	SOUTH TX COMMUNICIATION	09/30/18	\$ 570.00	RESET VHF RADIOS-FIRE EMERGENCY RADIOS
33203	SPEEDTECH LIGHTS	09/30/18	\$ 760.69	POLICE DEPT LIGHTS FOR POLARIS ATV'S
33204	SUSANA ESCOBEDO	11/08/18	\$ 27.52	REIMBURSE MILES-READING OUTREACH PROGRAM 10/23-1
33205	TIGER MEDICAL	10/11/18	\$ 158.44	CPR PADS-AED
33206	TMCCP	11/16/18	\$ 295.00	TCCMP ELECTION LAW SEMINAR-J.MOYA FRISCO TX, 1/24-1
33207	WATCH GUARD	09/30/18	\$ 41,225.00	IN CAR VIDEO RECORDING SYSTEM-POLICE DEPT
33208	ZARSKY LUMBER	10/31/18	\$ 754.63	OCT 2018-SUPPLIES FOR MAINT/ASPHALT PATCH-STREET I
33209	LIZBETH CHAPA ZUNIGA	11/21/18	\$ 100.00	REISSUE CHECK-RENTAL DEPOSIT REFUND
		TOTAL	\$ 527,136.20	

CITY OF LOS FRESNOS
 REVENUE & EXPENSE REPORT (UNAUDITED)
 AS OF: NOVEMBER 30TH, 2018

1.7.1.a

Handwritten initials/signature

01 -GENERAL FUND
 FINANCIAL SUMMARY

% OF YEAR COMPLETED: 16.67

	CURRENT BUDGET	CURRENT PERIOD	YEAR TO DATE ACTUAL	TOTAL ENCUMBERED	BUDGET BALANCE	% YTD BUDGET
<u>REVENUE SUMMARY</u>						
00-PROPERTY TAXES	1,629,826	68,898.82	1,030,383.97	0.00	599,442.03	63.22
30-NONPROPERTY TAXES	1,427,093	135,455.87	270,063.27	0.00	1,157,029.73	18.92
07-POLICE	575,620	24,407.37	59,376.81	0.00	516,243.19	10.32
10-HEALTH	7,800	370.00	870.00	0.00	6,930.00	11.15
12-GARBAGE	131,000	73,954.18	86,783.98	0.00	44,216.02	66.25
15-PARKS	23,500	0.00	0.00	0.00	23,500.00	0.00
16-LIBRARY	12,000	904.15	1,897.65	0.00	10,102.35	15.81
44-Misc Revenue	20,000	2,227.06	3,247.06	0.00	16,752.94	16.24
90-REIMBURSABLES	212,382	0.00	11,076.75	0.00	201,305.25	5.22
TOTAL REVENUES	4,039,221	306,217.45	1,463,699.49	0.00	2,575,521.51	36.24
<u>EXPENDITURE SUMMARY</u>						
02-ADMINISTRATION	503,781	34,590.61	64,261.11	6,038.16	433,481.33	13.95
03-MUNICIPAL COURT	229,740	7,101.66	22,010.55	0.00	207,729.45	9.58
04-TAX ASSESSOR COLLECTOR	39,737	619.23	10,131.80	0.00	29,605.20	25.50
06-ELECTIONS	18,098	0.00	315.00	0.00	17,783.00	1.74
07-POLICE	1,582,383	44,856.89	169,601.41	8,231.05	1,404,550.30	11.24
08-FIRE	122,457	451.00	24,252.31	0.00	98,204.25	19.80
09-ENGINEERING	65,000	0.00	2,621.79	0.00	62,378.21	4.03
10-HEALTH	136,539	2,140.10	8,118.49	730.00	127,690.47	6.48
11-EMERGENCY MEDICAL SERV	152,957	0.00	35,679.08	0.00	117,278.02	23.33
12-GARBAGE	5,500	0.00	872.38	0.00	4,627.62	15.86
13-STORM WATER	22,500	0.00	156.53	120.00	22,223.47	1.23
14-STREETS	328,376	4,750.29	38,814.86	518.36	289,043.26	11.98
15-PARKS	358,093	3,626.26	19,169.57	8,200.20	330,723.05	7.64
16-LIBRARY	224,609	5,000.72	22,413.90	0.00	202,195.24	9.98
17-COMMUNITY CENTER	13,661	339.66	1,207.67	17.29	12,436.04	8.97
18-EMERGENCY MANAGEMENT	42,000	579.55	17,463.55	18,386.16	6,150.29	85.36
19-ALL DEPARTMENT EXPENS	14,600	0.00	208.22	0.00	14,391.78	1.43
21-CITY PROMOTION	4,500	1,500.00	1,500.00	0.00	3,000.00	33.33
23-DSRIP-COMMUNITY HEALT	46,901	1,739.44	5,254.56	0.00	41,646.44	11.20
24-MENTAL TASK FORCE PRO	62,831	2,470.79	7,565.24	0.00	55,265.76	12.04
28-INFORMATION TECHNOLOG	64,953	1,889.95	6,649.82	90.00	58,213.18	10.38
TOTAL EXPENDITURES	4,039,215	111,656.15	458,267.84	42,331.22	3,538,616.36	12.39
REVENUE OVER/(UNDER) EXPENDITURES	6	194,561.30	1,005,431.65	(42,331.22)	(963,094.85)	9,864.34

Attachment: CC FINANCIAL REPORT [Revision 1] (2846 : Financial Report)

CHECKLIST FOR WATER & SEWER				NOVEMBER 2018
CK #	VENDOR NAME	Inv.Date	Amount	Description
224	CITY OF L.F. PAYROLL ACCT	11/01/18	\$ 31,882.18	DUE TO PAYROLL #2 11/2/18
233	CITY OF L.F. PAYROLL ACCT	11/15/18	\$ 32,771.00	DUE TO PAYROLL #3 11/16/18
236	CITY OF L.F. PAYROLL ACCT	11/29/18	\$ 27,651.84	DUE TO PAYROLL #4 11/30/18
148156	AGUAWORKS	10/19/18	\$ 191.64	12-PLASTIC WATER METER BOXES
148157	ANA-LAB	10/24/18	\$ 99.00	TOC-RAW/WATER PLANT- WATER TESTING
148158	AQUA METRIC SALES	11/01/18	\$ 2,822.92	3- 2"-OMNI WATER METERS
148159	BICKERSTAFF HEALTH	10/15/18	\$ 3,629.87	ATTORNEY FEES-EAST RIO HONDO
148160	CCID#6	10/31/18	\$ 736.90	OCT 2018-RAW WATER
148161	CHEMTRADE CHEMICALS	10/09/18	\$ 4,262.65	LIQUID ALUM BLEND-WATER PLANT CHEMICALS
148162	CINTAS CORPORATION	VARIOUS	\$ 1,042.88	CLEANING-WATER/SEWER UNIFORMS
148163	CINTAS CORPORATION	10/29/18	\$ 161.12	MEDICAL SUPPLIES-PUBLIC WORKS
148164	CITY OF LOS FRESNOS	10/20/18	\$ 123.28	WATER SERVICE-SEWER PLANT/LIFT STATION
148165	CORE & MAIN LP	09/30/18	\$ 20,555.56	2- LIFT STATION PUMPS-HS LIFT STATION/N.ARROYO LIFT STATIC
148166	EAST RIO HONDO WATER	11/09/18	\$ 962.09	NOV 2018-ERH SETTLEMENT
148167	FUELMAN	VARIOUS	\$ 570.83	FUEL FOR WATER/SEWER VEHICLES
148168	HACH CHEMICAL	10/23/18	\$ 811.51	NITRATE CHEMKEYS FOR ANALYZERS
148169	HANSON PROFESSIONAL	09/30/18	\$ 6,784.00	2018-WWTP PERMIT RENEWAL
148170	HECTOR'S MUFFLER	11/06/18	\$ 1,394.87	REPLACE RADIATOR,TIMING COVERSET,OIL COOKER GASKET-WV
148171	INTEGRITY TESTING	11/02/18	\$ 970.00	OCT 2018-SEWER PLANT TESTING
148172	LUIS MASCORRO	10/31/18	\$ 530.00	REPAIR AERATOR MOTOR WIREING-SOUTH BASIN-WWTP
148173	PRAXAIR	10/22/18	\$ 36.27	CHEMICAL/CYLINDER RENTAL
148174	PROTECTION ONE ALARM	10/18/18	\$ 283.00	ANNUAL FIRE EXTINGUISHER INSPECTION/REPLACE EXTINGISHER
148175	PURCHASE POWER	09/30/18	\$ 851.41	SEPT 2018-POSTAGE-WATER BILLS/LATE NOTICES
148176	RIO GRANDE VALLEY INDUSTRI	10/28/18	\$ 7,839.00	REPAIR SEALS ON HIGH SERVICE PUMPS/REPAIR FILTER PUMPS
148177	SANCHEZ SERVICES	10/01/18	\$ 5.00	WS-061-FLAT TIRE REPAIR
148178	TX COALITION OF CITIES	10/15/18	\$ 313.20	2019-RENEWAL DUES
148179	TX COMMISION OF ENVIRONMENTAL	10/31/18	\$ 8,938.12	2019 WWTP PERMIT/WATER RIGHTS ASSESSMENT-2019
148180	TYLER TECHNOLOGIES	11/01/18	\$ 5,268.60	ANNUAL SOFTWARE MAINT-UTILITY CIS/CASH COLLECTION
CHECKS 148181-148190				UTILITY DEPOSIT REFUND CHECKS
148191	AGUAWORKS	VARIOUS	\$ 527.71	SUPPLIES FOR LIFT STATIONS
148192	AMAZON.COM	VARIOUS	\$ 137.86	FULL RESPIRATORS/RESPIRATOR FILTERS/POCKET DIVIDERS-EM
148193	ANA-LAB	11/15/18	\$ 132.00	TOC WATER TESTING-RAW, WATER PLANT, COMBINED SAMPLES
148194	AT&T SOUTHWESTERN BELL	11/01/18	\$ 1,516.15	REPAIR DAMAGE PHONE LINE-SEWER REPAIRS 33253 CACTUS R
148195	AT&T MOBILITY	11/01/18	\$ 361.10	MOBILE PHONE SERVICE
148196	CDW GOVERNMENT	11/06/18	\$ 1,206.49	NETWORK SWITCHES
148197	CHEMTEX INDUSTRIES	11/08/18	\$ 155.00	5 GALLONS-ODOR CONTROL-LIFT STATION MAINTENANCE
148198	DATA MANAGEMENT	11/12/18	\$ 753.32	TIME CLOCK SOFTWARE MAINTENANCE
148199	DEPARTMENT OF STATE HEALTH	11/01/18	\$ 52.92	6 ROUTINE WATER SAMPLES
148200	DIRECT ENERGY	10/29/18	\$ 9,349.67	ELECTRICITY-WATER/SEWER
148201	EAST RIO HONDO WATER	VARIOUS	\$ 281.40	WATER SERVICE-EDAP LIFT STATIONS
148202	EDWARD'S PEST MANAGEMENT	11/08/18	\$ 29.00	PEST CONTROL-SERVICE CENTER
148203	FERGUSTON ENTERPRISES	11/08/18	\$ 480.00	2" GATE VALVE-REPAIRS ON COMA & EAST 5TH
148204	FRED PRYOR SEMINARS	11/15/18	\$ 298.50	PRYOR PLUS MEMBERSHIP-R.RODRIGUEZ/D.RATLIFF/K.HOUSE
148205	FUELMAN	11/04/18	\$ 322.55	FUEL FOR WATER/SEWER VEHICLES
148206	LUIS MASCORRO	VARIOUS	\$ 800.00	REPAIRS TO BINGLY LIFT STATION PUMPS/N.CLARIFIER RETURN
148207	MAGIC VALLEY ELECTRIC	11/13/18	\$ 63.30	ELECTRICITY-LIFT STATION-CACTUS ROAD
148208	MAXIMINO TORRES	11/21/18	\$ 176.00	CLEANING OF WATER/SEWER VEHICLES
148209	O'REILLY AUTO	VARIOUS	\$ 876.66	OCT 2018-SUPPLIES FOR MAINTENANCE
148210	O'REILLY AUTO	VARIOUS	VOID	VOIDED CHECK-CONTINUED
148211	SMARTCOM TELEPHON	11/08/18	\$ 141.64	INTERNET SERVICE-WATER/SEWER DEPT
148212	TEXAS WATER UTILITES ASSOCIA	11/07/18	\$ 75.00	MEMBERSHIP NEWAL -2019 CITRUS DISTRICT
148213	ZARSKY LUMBER	10/31/18	\$ 366.05	OCT 2018-SUPPLIES FOR MAINTENANCE
TOTAL			\$ 179,591.06	

Attachment: CC FINANCIAL REPORT [Revision 1] (2846 : Financial Report)

UTILITY DEPOSIT REFUND CHECKS				
148181	BATES, JOHN & DONNA	11/09/18	\$ 111.74	ACCT #01-12050-04 UTILITY DEPOSIT REFUND
148182	FONSECA, JESUS	11/09/18	\$ 27.53	ACCT #01-15300-05 UTILITY DEPOSIT REFUND
148183	CRUZ, ISMAEL J	11/09/18	\$ 108.63	ACCT #02-21482-00 UTILITY DEPOSIT REFUND
148184	HERNANDEZ, CLAUDIA	11/09/18	\$ 8.48	ACCT #02-21529-06 UTILITY DEPOSIT REFUND
148185	RODRIGEZ, ROCIO	11/09/18	\$ 19.69	ACCT #03-03442-11 UTILITY DEPOSIT REFUND
148186	LONGORIA, MARIA DE LOURDE	11/09/18	\$ 124.36	ACCT #03-18840-13 UTILITY DEPOSIT REFUND
148187	ALVAREZ, STEVEN	11/09/18	\$ 119.20	ACCT #03-18840-14 UTILITY DEPOSIT REFUND
148188	ESPINOZA, MOISES	11/09/18	\$ 10.91	ACCT #03-20263-05 UTILITY DEPOSIT REFUND
148189	GLOBAL HOME FINDERS REALTY	11/09/18	\$ 109.93	ACCT #03-20348-03 UTILITY DEPOSIT REFUND
148190	STEWART, VICKIE LEE	11/09/18	\$ 114.97	ACCT #03-29830-04 UTILITY DEPOSIT REFUND
		TOTAL	\$ 755.44	

CITY OF LOS FRESNOS
 REVENUE & EXPENSE REPORT (UNAUDITED)
 AS OF: NOVEMBER 30TH, 2018

1.7.1.a

05 - UTILITY FUND
 FINANCIAL SUMMARY

% OF YEAR COMPLETED: 16.67

	CURRENT BUDGET	CURRENT PERIOD	YEAR TO DATE ACTUAL	TOTAL ENCUMBERED	BUDGET BALANCE	% YTD BUDGET
<u>REVENUE SUMMARY</u>						
00-REVENUES	2,718,750	197,359.66	390,452.98	0.00	2,328,297.02	14.36
TOTAL REVENUES	2,718,750	197,359.66	390,452.98	0.00	2,328,297.02	14.36
<u>EXPENDITURE SUMMARY</u>						
02-WATER ADMINISTRATION	568,234	16,519.39	61,000.33	1,134.89	506,099.15	10.93
05-INFORMATION TECHNOLOG	32,477	944.98	3,242.94	45.00	29,188.58	10.12
26-WATER SUPPLIES	121,500	616.74	12,030.91	10,115.91	99,353.18	18.23
27-MAINTENANCE OF WATER S	13,658	29.00	484.80	343.14	12,830.06	6.06
28-MAINTENANCE OF WATER E	56,300	4,016.43	9,898.52	8,268.00	38,133.48	32.27
29-WATER PURCHASES	38,138	0.00	3,181.14	0.00	34,956.86	8.34
30-WATER MISCELLANEOUS EX	481,149	3,010.96	119,312.96	53,695.72	308,140.32	35.96
20-CAPITAL OUTLAY	15,000	2,822.92	4,606.35	1,477.44	8,916.21	40.56
32-WATER BONDED INDEBTEDN	174,594	0.00	52,390.00	0.00	122,204.00	30.01
34-SEWER ADMINISTRATION	659,131	16,789.09	65,624.60	1,134.88	592,371.89	10.13
35-INFORMATION TECHNOLOG	32,252	944.97	3,242.92	45.00	28,964.10	10.19
36-SEWER SUPPLIES	73,150	1,197.64	4,780.25	155.02	68,214.73	6.75
37-MAINTENANCE OF SEWER S	13,049	155.00	816.39	521.37	11,711.24	10.25
38-MAINTENANCE OF SEWER E	71,158	3,292.39	9,411.01	4,385.82	57,361.17	19.39
39-SEWER MISC. EXPENSES	536,500	3,010.96	11,460.18	0.00	525,039.82	2.14
41-SEWER BONDED INDEBTEDN	61,473	0.00	0.00	0.00	61,472.60	0.00
52-TRANSFER OUT	495,988	0.00	0.00	0.00	495,987.75	0.00
TOTAL EXPENDITURES	3,443,751	53,350.47	361,483.30	81,322.19	3,000,945.14	12.86
REVENUE OVER/(UNDER) EXPENDITURES	(725,001)	144,009.19	28,969.68	(81,322.19)	(672,648.12)	7.22

Attachment: CC FINANCIAL REPORT [Revision 1] (2846 : Financial Report)

CHECKLIST FOR CDC				NOVEMBER 2018
CK #	VENDOR NAME	Inv.Date	Amount	Description
2563	ARCHER BUSINESS SYSTEMS	10/31/18	\$ 9.22	COLOR COPIES-CDC
2564	DESIDERIO MARTINEZ	11/02/18	\$ 1,015.38	10/22-11/2/18-SERVICE AGREEMENT
2565	GRANICUS	10/30/18	\$ 82.95	OCT-AGENDA/MINUTE-IQM2 SUBSCRIP
2566	GULF COAST SIGN COMPANY	09/30/18	\$ 2,205.53	GRANT-SIGN FOR LFVFD & LFEMS
2567	JAMES HARRIS III	11/09/18	\$ 120.00	10/29-11/9/18- WEB SITE UPDATES
2568	SOUTH TX NATURE	10/01/18	\$ 550.00	S. TX NATURE ANNUAL PARTICIPATION 2019
2569	DESIDERIO MARTINEZ	11/16/18	\$ 1,015.38	11/5-11/16/18 SERVICE AGREEMENT
2570	GRANICUS	11/01/18	\$ 82.95	AGENDA/MINUTE-IQM2 MONTHLY SUBSCRIPT
2571	JAMES HARRIS III	11/21/18	\$ 120.00	11/12-11/21/18 WEB SITE UPDATES
2572	LOS FRESNOS CHAMBER OF COMM	11/12/18	\$ 500.00	2018-CHRISTMAS FEST/PARADE SPONSOR
		TOTAL	\$ 5,701.41	

Attachment: CC FINANCIAL REPORT [Revision 1] (2846 : Financial Report)

[Handwritten signature]
11/22/18

CITY OF LOS FRESNOS
 REVENUE & EXPENSE REPORT (UNAUDITED)
 AS OF: NOVEMBER 30TH, 2018

1.7.1.a

09 -COMMUNITY DEVELOPMENT COR
 FINANCIAL SUMMARY

% OF YEAR COMPLETED: 16.67

	CURRENT BUDGET	CURRENT PERIOD	YEAR TO DATE ACTUAL	TOTAL ENCUMBERED	BUDGET BALANCE	% YTD BUDGET
<u>REVENUE SUMMARY</u>						
52-CDC DISBURSEMENTS	351,250	31,669.44	67,557.85	0.00	283,692.15	19.23
TOTAL REVENUES	351,250	31,669.44	67,557.85	0.00	283,692.15	19.23
<u>EXPENDITURE SUMMARY</u>						
52-CDC DISBURSEMENTS	351,250	2,853.71	6,886.74	4,380.74	339,982.50	3.21
TOTAL EXPENDITURES	351,250	2,853.71	6,886.74	4,380.74	339,982.50	3.21
REVENUE OVER/(UNDER) EXPENDITURES	0	28,815.73	60,671.11	(4,380.74)	(56,290.35)	1,850.00

Attachment: CC FINANCIAL REPORT [Revision 1] (2846 : Financial Report)

Sales Tax Report
FY18-19

Paid	2c			1-1/2c (General Fund Portion)			1/2c (CDC Portion)					
	FY17-18	FY 16-17	Inc(Dec) (\$)	Inc(Dec) (%)	FY 16-17	FY 15-16	Inc(Dec) (\$)	Inc(Dec) (%)	FY 16-17	FY 15-16	Inc(Dec) (\$)	Inc(Dec) (%)
October	114,509.39	116,427.55	(1,918.16)	-1.65%	85,882.04	87,320.66	(1,438.62)	-1.65%	28,627.35	29,106.89	(479.54)	-1.65%
November	109,338.63	111,307.74	(1,969.11)	-1.77%	82,003.97	83,480.81	(1,476.83)	-1.77%	27,334.66	27,826.94	(492.28)	-1.77%
December	103,195.45	99,756.63	3,438.82	3.45%	77,396.59	74,817.47	2,579.11	3.45%	25,798.86	24,939.16	859.70	3.45%
January	110,304.96	105,242.57	5,062.39	4.81%	82,728.72	78,931.93	3,796.79	4.81%	27,576.24	26,310.64	1,265.60	4.81%
February	131,130.82	120,436.21	10,694.61	8.88%	98,348.12	90,327.16	8,020.96	8.88%	32,782.71	30,109.05	2,673.65	8.88%
March	99,829.00	92,985.80	6,843.20	7.36%	74,871.75	69,739.35	5,132.40	7.36%	24,957.25	23,246.45	1,710.80	7.36%
April	100,976.00	99,592.03	1,383.97	1.39%	75,732.00	74,694.02	1,037.98	1.39%	25,244.00	24,898.01	345.99	1.39%
May	142,667.08	109,681.62	32,985.46	30.07%	107,000.31	82,261.22	24,739.10	30.07%	35,666.77	27,420.41	8,246.37	30.07%
June	109,989.07	115,642.66	(5,653.59)	-4.89%	82,491.80	86,732.00	(4,240.19)	-4.89%	27,497.27	28,910.67	(1,413.40)	-4.89%
July	125,789.13	128,747.63	(2,958.50)	-2.30%	94,341.85	96,560.72	(2,218.88)	-2.30%	31,447.28	32,186.91	(739.63)	-2.30%
August	134,113.34	114,408.47	19,704.87	17.22%	100,585.01	85,806.35	14,778.65	17.22%	33,528.34	28,602.12	4,926.22	17.22%
September	124,334.26	121,504.14	2,830.12	2.33%	93,250.70	91,128.11	2,122.59	2.33%	31,083.57	30,376.04	707.53	2.33%
TOTAL SALES ACTIVITIES	\$ 1,406,177.13	\$ 1,335,733.05	\$ 74,331.35	5.27%	\$ 1,054,632.85	\$ 1,001,799.79	\$ 55,748.51	5.27%	\$ 351,544.28	\$ 333,933.26	\$ 18,582.84	5.27%

Paid	2c			1-1/2c (General Fund Portion)			1/2c (CDC Portion)					
	FY18-19	FY17-18	Inc(Dec) (\$)	Inc(Dec) (%)	FY 17-18	FY 16-17	Inc(Dec) (\$)	Inc(Dec) (%)	FY 17-18	FY 16-17	Inc(Dec) (\$)	Inc(Dec) (%)
October	142,634.96	114,509.39	28,125.57	24.56%	106,976.22	85,882.04	21,094.18	24.56%	35,658.74	28,627.35	7,031.39	24.56%
November	126,677.77	109,338.63	17,339.14	15.86%	95,008.33	82,003.97	13,004.36	15.86%	31,669.44	27,334.66	4,334.79	15.86%
December		103,195.45		0.00%		77,396.59		0.00%		\$ 25,798.86		0.00%
January		110,304.96		0.00%		82,728.72		0.00%		27,576.24		0.00%
February		131,130.82		0.00%		98,348.12		0.00%		32,782.71		0.00%
March		99,829.00		0.00%		74,871.75		0.00%		24,957.25		0.00%
April		100,976.00		0.00%		75,732.00		0.00%		25,244.00		0.00%
May		142,667.08		0.00%		107,000.31		0.00%		35,666.77		0.00%
June		109,989.07		0.00%		82,491.80		0.00%		27,497.27		0.00%
July		125,789.13		0.00%		94,341.85		0.00%		31,447.28		0.00%
August		134,113.34		0.00%		100,585.01		0.00%		33,528.34		0.00%
September		124,334.26		0.00%		93,250.70		0.00%		31,083.57		0.00%
TOTAL SALES ACTIVITIES	\$ 269,312.73	\$ 1,406,177.13	\$ 45,464.71	20.31%	\$ 201,984.55	\$ 1,054,632.85	\$ 34,098.53	20.31%	\$ 67,328.18	\$ 351,544.28	\$ 11,366.18	20.31%

**** Sales Tax Amount may be adjusted a the end of the year based on actuals sales activity amounts.

Sales Tax Revenue Comparison

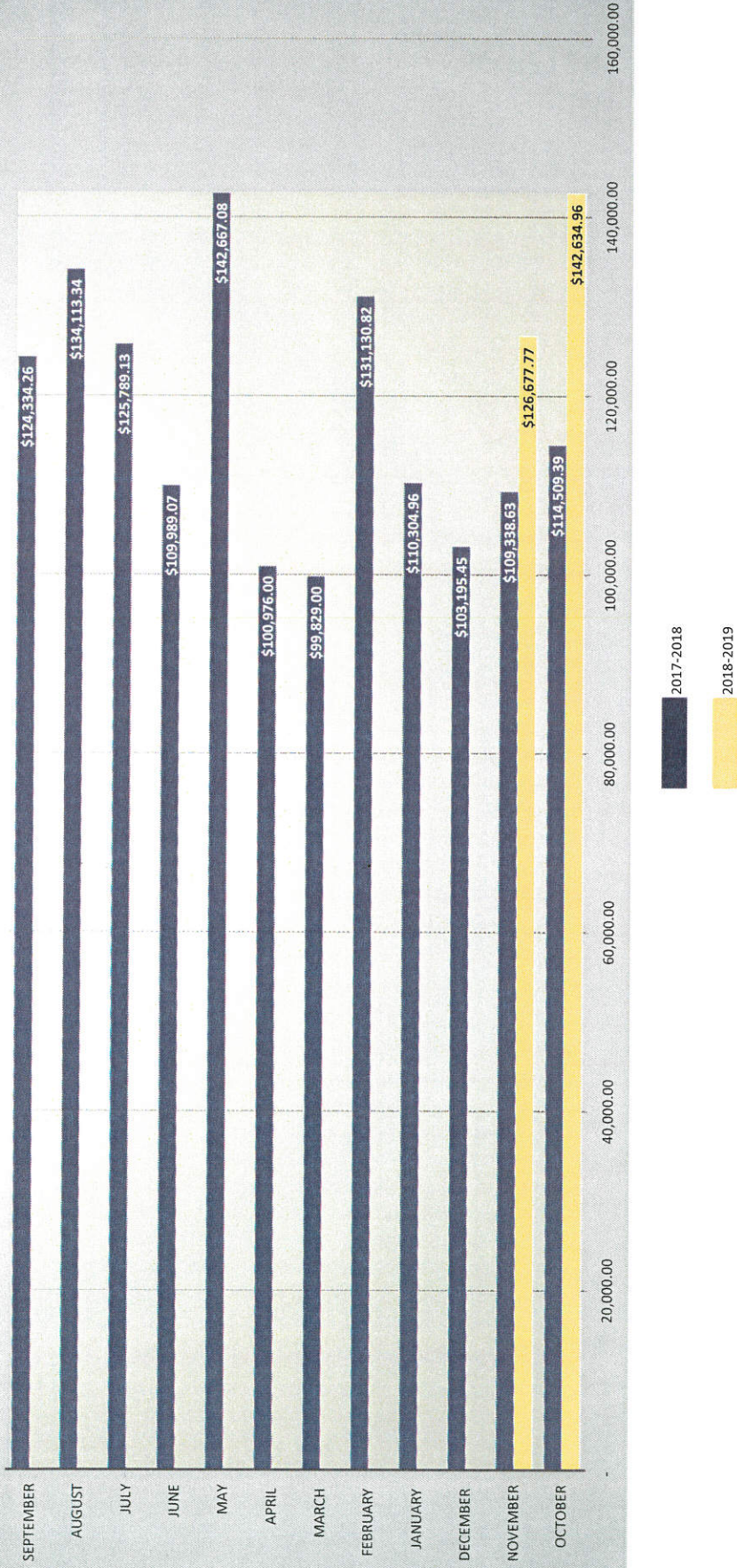

City Council
200 North Brazil
Los Fresnos, TX 78566

Meeting: 12/11/18 06:00 PM
Department: City Secretary
Category: Report
Prepared By: Jacqueline Moya
Initiator: Jacqueline Moya
Sponsors:
DOC ID: 2847

SCHEDULED

ACTION ITEM (ID # 2847)

**Public Works Report 1. Water and Wastewater Activity 2.
Calls for Service 3. Building Permits 4. Recycling**

Call with questions.

I recommend approval.

**City of Los Fresnos
Water Treatment Plant
And
Wastewater Treatment Plant**

Activity for the month of November 2018

Water Treatment Plant

Total Output: 15,113,340
Daily Average: 487,527
% of Capacity: 48.7%

Waste Water Treatment Plant

Total Output: 15,620,000
Daily Average: 503,871
% of Capacity: 50.3%

Attachment: PW (2847 : Public Works Report)

CITY OF LOS FRESNOS
PUBLIC WORKS DEPARTMENT
MONTHLY REPORT
NOVEMBER 2018

CALLS FOR SERVICE	MONTH TOTAL	YEAR TO DATE
Service Connects/Disconnects	91	992
Rereads/Meter Info	65	1135
Water Taps	3	16
Sewer Taps	0	0
Change Meter	1	71
Service Check for Water Leak at Account	8	137
Repaired Leak	2	26
Call for Sewer Stoppage	12	105
City Sewer Lines Unstopped	9	77
Code Enforcement/Other	51	801
Pothole Repairs	144	1041
Street Repairs	0	6
Street Sign Replacement/Repaired	0	27
Asphalt Used (ton)	4	20.35
Gravel Used (ton)	3.3	23.3
Fire Hydrants Flushed and Oiled	6	282
Fire Hydrants Repaired	0	5
Valves Repaired	1	4
Manholes Cleaned/Repaired	6	41

 Carlos Salazar, Director of Public Works

PROJECTS: 0 -ZZZZZZZZZZ
 APPLIED DATES: 0/00/0000 THRU 99/99/9999
 ISSUED DATES: 11/01/2018 THRU 11/30/2018
 EXPIRE DATES: 0/00/0000 THRU 99/99/9999
 STATUS: ALL

1.7.2.c

PROJECT	ISSUE DATE	NAME	LOCATION	CONTRACTOR	DESCRIPTION	PROJ TYPE
131438	11/02/2018	QUINTANILLA, ALICIA	114 CANAL STREET	HUGO	RESIDENTIAL REMODEL/ADDITIO	ALT
131439	11/02/2018	CONEJO, LEOPOLDO	101 EBONY STREET	BETHEL	ELECTRICAL PERMIT	ALT
131440	11/06/2018	DELGADO, ROBERTO	733 W OCEAN BLVD	DELGADO EC	RESIDENTIAL BUILDING	NEW
131441	11/06/2018	STARS RESTAURANT	747 W OCEAN BLVD	OWNER	COMMERCIAL ADDITION/REMODEL	ALT
131442	11/08/2018	SALDANA, SAMUEL	110 RESACA RETREAT DRIVE	OWNER	EXTEND DRIVEWAY	ALT
131443	11/08/2018	GUZMAN, JUAN	410 E OCEAN BLVD	TEXAS SEC	FENCE PERMIT	ALT
131444	11/08/2018	SALDIVAR, CRISTIAN	609 W 7TH STREET	OWNER	RESIDENTIAL REMODEL/ADDITIO	ALT
131445	11/13/2018	ALFREDO'S JR	506 S ARROYO BLVD	OWNER	COMMERCIAL- NEW OWNER/TENAN	ALT
131446	11/13/2018	SIBAJA, ROBERTO	411 VALLEY OAK CIRCLE	OWNER	RESIDENTIAL REMODEL/ADDITIO	ALT
131447	11/13/2018	OCEAN INSPECTION	123 W OCEAN BLVD # 5	OWNER	COMMERCIAL- NEW OWNER/TENAN	ALT
131448	11/14/2018	FERNANDEZ, IMPERIO S	30910 STATE HWY 100 LT4	OWNER	MOVING PERMIT	MOVING
131449	11/16/2018	BLANCO LUNA & ASSOCIATES, L	315 N. ARROYO BLVD.	OWNER	COMMERCIAL ADDITION/REMODEL	ALT
131450	11/26/2018	REAL ESTATE OUTFITTERS INC	208 N ARROYO BLVD	OWNER	COMMERCIAL- NEW OWNER/TENAN	ALT
131451	11/26/2018	TNT FUENTES MMA	208 N ARROYO BLVD B	OWNER	COMMERCIAL- NEW OWNER/TENAN	ALT
131452	11/28/2018	AAP DESIGN & CONSTRUCTION	313 E 2ND STREET A&B	OWNER	RESIDENTIAL BUILDING	NEW
131453	11/28/2018	GONZALEZ, ROSA E	405 VALLEY OAK CIRCLE	AAP	RESIDENTIAL BUILDING	NEW
131454	11/28/2018	PARRA'S TAMALES Y MAS	315 N ARROYO BLVD 1	OWNER	SIGN PERMIT	S
131455	11/29/2018	EASY SOLUTIONS	511 E OCEAN STE 103	OWNER	COMMERCIAL- NEW OWNER/TENAN	ALT
131456	11/29/2018	BURGERIM	31260 STATE HWY 100	OWNER	SIGN PERMIT	S
131457	11/29/2018	URIE, MIGUEL	315 E 2ND STREET A	OWNER	RESIDENTIAL BUILDING	NEW

*** TOTALS *** NUMBER OF PROJECTS: 20 VALUATION: 476,000.00 FEES: 11,222.50

Attachment: BP Valuation Report - 4369 (2847 : Public Works Report)

PROJECTS: 0 -ZZZZZZZZZZ
 APPLIED DATES: 0/00/0000 THRU 99/99/9999
 ISSUED DATES: 11/01/2018 THRU 11/30/2018
 EXPIRE DATES: 0/00/0000 THRU 99/99/9999
 STATUS: ALL

1.7.2.c

*** SEGMENT RECAP ***

PROJECT SEGMENT - DESCRIPTION	# OF SEGMENTS	VALUATION	FEE
B - BUILDING PERMIT	6	37,000.00	642.50
CERT - CERTIFICATE OF OCCUPANCY	1	0.00	60.00
COMM - COMM: NEW OWNER/TENANT	5	0.00	360.00
E - ELECTRICAL PERMIT	3	0.00	501.00
EXPDRIVE - EXPANSION OF DRIVEWAY	1	3,200.00	71.00
M - MECHANICAL PERMIT WAY	1	0.00	75.00
MOVING - MOVING PERMIT	1	0.00	160.00
N - BUILDING PERMIT	4	430,000.00	8,630.00
P - PLUMBING PERMIT	3	0.00	445.00
SIGN - SIGN PERMIT	2	5,800.00	278.00
*** TOTALS ***	27	476,000.00	11,222.50

Attachment: BP Valuation Report - 4369 (2847 : Public Works Report)

PROJECTS: 0 -ZZZZZZZZZZ
 APPLIED DATES: 0/00/0000 THRU 99/99/9999
 ISSUED DATES: 11/01/2018 THRU 11/30/2018
 EXPIRE DATES: 0/00/0000 THRU 99/99/9999
 STATUS: ALL

1.7.2.c

*** BUILDING CODE RECAP ***

BUILDING CODE - DESCRIPTION	# OF PROJECTS	# OF SEGMENTS	VALUATION	FEE\$
BLANK - *BLANK*	9	13	5,800.00	1,434.00
101 - SINGLE FAMILY ATTACHED	8	11	249,400.00	3,364.50
103 - TWO-FAMILY RESIDENCE	2	2	215,000.00	6,340.00
440 - COMMERCIAL REPAIRS	1	1	5,800.00	84.00
*** TOTALS ***	20	27	476,000.00	11,222.50

Attachment: BP Valuation Report - 4369 (2847 : Public Works Report)

**City of Los Fresnos
Recycling Program
Total Number of Guest
November 2018**

Date	Tuesdays at Memorial Park
11/06/17	32
11/13/17	28
11/20/17	21
11/27/17	26
Totals	107

Date	Thursdays at Community Park
11/01/18	26
11/08/18	23
11/15/18	30
11/22/18	0
11/29/18	29
Totals	108

Date	Saturdays at City Hall
11/03/18	31
11/10/18	28
11/17/18	24
11/24/18	0
Totals	83

Total attendance for the Month of November	298
---	------------

Attachment: Recycling Program 2018-2019 (2847 : Public Works Report)

City Council
200 North Brazil
Los Fresnos, TX 78566

Meeting: 12/11/18 06:00 PM
Department: City Secretary
Category: Report
Prepared By: Jacqueline Moya
Initiator: Jacqueline Moya
Sponsors:
DOC ID: 2848

SCHEDULED

ACTION ITEM (ID # 2848)

Police Department 1. Arrests 2. Incidents 3. Accidents

Call with questions.

I recommend approval.

LOS FRESNOS POLICE DEPARTMENT

Arrests - By Violation

11\01\2018
thru 11\30\2018

Violation	# of Offenses
ASSAULT CAUSES BODILY INJ 13c	1
ASSAULT CAUSES BODILY INJURY FAMILY VIOLENCE 13a	2
DRIVING WHILE INTOXICATED	5
DRIVING WHILE INTOXICATED 3RD OR MORE	1
EXECUTION OF CAPIAS OR ARREST WARRANT	5
FICTITIOUS LP/REGISTRATION/SI	1
HOLD FOR CUSTOMS	1
INTERFER W/EMERGENCY CALL	1
NO DRIVER'S LICENSE	1
POSS CS PG 2 <1G DRUG FREE ZONE	1
POSS MARIJ <2OZ	3
PUBLIC INTOXICATION	3
THEFT PROP>=\$1,500<\$20K 23a	1
THEFT PROP>=\$50<\$500 23a	2
UNLAWFUL RESTRAINT	1
Total Violations	29
Total Arrests	27

Attachment: arrests nov (2848 : Police Department)

LOS FRESNOS POLICE DEPARTMENT

Incidents - By Violation

11\01\2018
thru 11\30\2018

Violation	Incidents
ABANDONED VEHICLES	26
ALARMS	14
ANIMAL CONTROL	32
ASSAULT CAUSES BODILY INJURY FAMILY VIOLENCE 13a	2
BURGLARY OF BUILDING	1
BURGLARY OF VEHICLE 23f	4
CHANGED LANE WHEN UNSAFE	1
CITY ORD VIOLATION	1
CREDIT CARD OR DEBIT CARD ABUSE	1
CRIMINAL TRESPASS	1
DEPOSITED GLASS/OTHER DEBRIS ON HIGHWAY	2
DOG AT LARGE	2
EXECUTION OF CAPIAS OR ARREST WARRANT	5
EXPLOITATION OF CHILD/ELDERLY/DISABLED	1
FAIL TO YIELD ROW FROM PRIVATE PROPERTY	1
GARAGE SALES	2
HARASSMENT	1
ILLEGAL DUMPING >5 LBS < 500 LBS	2
INTERFER W/EMERGENCY CALL	1
LOUD NOISE	5
MINOR IN POSSESSION OF ALCOHOL	1
NO DRIVER'S LICENSE	1
NO PROOF OF FINANCIAL RESPONSIBILITY	1
POSS MARIJ <2OZ	1
POSSESSION OF DRUG PARAPHERNALIA	2
PUBLIC INTOXICATION	3
STANDING IN PROHIBITED AREA	1
TERRORISTIC THREAT 13a	1
THEFT	7
THEFT PROP>=\$50<\$500 23a	2
UNLAWFUL RESTRAINT	1
WEEDED OR RUBBISH LOT	15
WELFARE CONCERN	4
Total Violations	145
Total Incidents	142

Attachment: incidents nov. 18 (2848 : Police Department)

LOS FRESNOS POLICE DEPARTMENT

Accident - By Street & Intersection

11\01\2018
thru 11\30\2018

Street & Intersection	Accidents	Fatalities	Vehicles	Injured
ARROYO & 2ND	1	0	2	0
ARROYO & OCEAN	1	0	0	0
ARROYO & WHIPPLE	1	0	0	0
FM 1575 & OCEAN	1	0	0	0
FM 803	1	0	0	0
OCEAN & NOGAL	1	0	2	0
OCEAN & ORIVE	1	0	0	0
STATE HWY 100	1	0	0	0
WHIPPLE & WHIPPLE	1	0	0	0
Total	9	0	4	0

Attachment: Accidents Nov. 18 (2848 : Police Department)

City Council
200 North Brazil
Los Fresnos, TX 78566

Meeting: 12/11/18 06:00 PM
Department: City Secretary
Category: Report
Prepared By: Jacqueline Moya
Initiator: Jacqueline Moya
Sponsors:
DOC ID: 2849

SCHEDULED

ACTION ITEM (ID # 2849)

Municipal Court 1. Monthly Report

Call with questions.

I recommend approval.

OFFICIAL MUNICIPAL COURT MONTHLY REPORT

MUNICIPAL COURT OF <u>Los Fresnos</u>	TRAFFIC		NON-TRAFFIC MISDEMEANOR	
	NON-PARKING	PARKING	STATE LAW	CITY ORDINANCE
FOR MONTH <u>November</u> YEAR <u>2018</u>				
1. New Cases Filed During the Month	<u>214</u>	<u>2</u>	<u>96</u>	<u>4</u>
2. Dispositions Prior to Trial:				
A. Bond Forfeitures				
B. Fined <i>(Before trial only. If the defendant goes to trial, enter in Item 3.)</i>				
C. Cases Dismissed <i>(Do not include dismissals that are to be reported in Items 3C and 4 below.)</i>				
3. Dispositions at Trial:				
A. Trial by Judge				
(1) Finding of Guilty	<u>115</u>		<u>13</u>	<u>1</u>
(2) Finding of Not Guilty				
B. Trial by Jury				
(1) Finding of Guilty				
(2) Finding of Not Guilty				
C. Dismissed at Trial	<u>9</u>		<u>3</u>	
4. Cases Dismissed:				
A. After Driver Safety Course <i>(C.C.P., Art. 45.0511)</i>	<u>56</u>			
B. After Deferred Disposition <i>(C.C.P., Art. 45.051)</i>	<u>25</u>			
C. After Proof of Financial Responsibility <i>(Transportation Code, Sec. 601.193)</i>	<u>8</u>			
D. Compliance Dismissal <i>(Proof of Inspection, License, or Registration)</i>	<u>22</u>			
5. Community Service Ordered <i>(For satisfaction of fine or costs only.)</i>	<u>4</u>			
6. Cases Appealed				
7. Juvenile / Minor Activity:				
A. Transportation Code Cases Filed	<u>1</u>			
B. Non-Driving Alcoholic Beverage Code Cases Filed	<u>1</u>			
C. Driving Under the Influence of Alcohol Cases Filed	<u>0</u>			
D. Health & Safety Code (Tobacco) Cases Filed	<u>1</u>			
E. Failure to Attend School Cases Filed <i>(Education Code, Sec. 25.094)</i>				
F. Education Code (Except Failure to Attend) Cases Filed				
G. Violation of Local Daytime Curfew Ordinance Cases Filed <i>(Loc. Govt. Code, Sec. 341.905)</i>				
H. All Other Non-Traffic Fine-Only Cases Filed	<u>6</u>			
I. Waiver of Jurisdiction of Non-Traffic Cases <i>(Family Code, Sec. 51.08(b))</i>				
J. Referred to Juvenile Court for Delinquent Conduct <i>(C.C.P., Art. 45.050 (c)(1))</i>				
K. Held in Contempt, Fined, or Denied Driving Privileges <i>(C.C.P., Art. 45.050 (c)(2))</i>				
Magistrate Warnings Given (Juvenile):				
L. Warnings Administered				
M. Statements Certified				
8. Parent Contributing to Nonattendance Cases Filed <i>(Education Code, Sec. 25.093)</i>				
9. Safety Responsibility and Driver's License Suspension Hearings Held				
10. Search Warrants Issued <i>(Do not include warrants for arrest.)</i>				
11. Arrest Warrants Issued:				
A. Class C Misdemeanors Only				<u>28</u>
B. Felonies and Class A and B Misdemeanors Only				
12. Magistrate Warnings Given: <i>(Given to defendants charged with county or district court offense.)</i>				
A. Class A and B Misdemeanors Only				<u>8</u>
B. Felonies				<u>1</u>
13. Emergency Mental Health Hearings Held				
14. Magistrate's Orders for Emergency Protection				
15. Total Revenue				<u>\$ 52,304.65</u>
<i>(Include all revenue collected during month to be remitted to)</i>				

Attachment: OFFICIAL MUN. COURT MONTHLY REPORT (2849 : Municipal Court)

City Council
200 North Brazil
Los Fresnos, TX 78566

Meeting: 12/11/18 06:00 PM
Department: City Secretary
Category: Report
Prepared By: Jacqueline Moya
Initiator: Jacqueline Moya
Sponsors:
DOC ID: 2850

SCHEDULED

ACTION ITEM (ID # 2850)

Library Report 1. Monthly Report

Call with questions.

I recommend approval.



ETHEL L. WHIPPLE MEMORIAL LIBRARY
LIBRARIAN'S REPORT
NOVEMBER 2018

Number of Patron Checking Out Materials

Adult	601
Children	111
Teens	13



Material Types Checked Out

Adult Books	189
Children Books	124
Young Adult Books	218
Videos	163
Audios	0
Other Language Books	16
Hotspots	27
Laptops	3



Items Downloaded

eBooks	38
eAudiobooks	7



Patron Access Computer Use

Total Sessions	391
Total Time	220 hours
Guest Passes	205



Free WiFi Access Use

Total Sessions	405 Library WiFi
Total Time	1,245 hours
Total Sessions	244 Park WiFi
Total Time	457 hours



What Happened In the Library

Hours Open	148 hours
Visits	2,250
Children Program Attendance	195
Volunteer Hours	65
New Cards Issued	13
Cards Renewed	59
New Books Added	66
New eBooks Added	263
New Videos Added	22
Hotspots Added	0
Books Weeded	29
Videos Weeded	0
Reference Questions	284
Assists in Computer Lab	223
Patron Copies	599
Patron Faxes sent	43
Patron Printouts	1,397
Library Staff Copies	1,482
Replacement Cards	12



City Council
200 North Brazil
Los Fresnos, TX 78566

Meeting: 12/11/18 06:00 PM
Department: City Secretary
Category: Report
Prepared By: Jacqueline Moya
Initiator: Jacqueline Moya
Sponsors:
DOC ID: 2851

SCHEDULED

ACTION ITEM (ID # 2851)

Fire Marshal's Report 1. Monthly Report

Call with questions.

I recommend approval.



FIRE MARSHAL'S OFFICE
200 NORTH BRAZIL
LOS FRESNOS, TEXAS 78566

FIRE INSPECTION REPORT

MONTHLY INFORMATION REPORT
MONTH OF NOVEMBER 2018

<u>FIRES</u>	<u>INSIDE CITY</u>	<u>OUTSIDE CITY</u>
Business Structures	_____	_____
Dwellings	_____	_____
Mobile Homes	_____	_____
Grass	_____	<u>1</u>
Refuse	_____	<u>2</u>
Institutional	_____	<u>1</u>
Motor Vehicles	_____	_____
Rescue Calls	_____	_____
Incendiary or Suspicious Fires	<u>2</u>	<u>9</u>
Other Calls	<u>2</u>	<u>5</u>
TOTAL ALARMS		<u>22</u>

MONTHLY FIRE PREVENTION INSPECTIONS

Commercial Businesses	<u>1</u>	Institutions	<u>2</u>
Industrial Structures	_____	Homes	<u>5</u>
Public Buildings	<u>2</u>	Apartments	_____
Hotels/Motels	_____		
TOTAL INSPECTIONS	<u>10</u>		

SCHOOL, HOSPITAL AND NURSING HOME FIRE DRILLS SUPERVISED: _____

LECTURES-PRESENTATIONS MADE/FILMS: SHOWN _____ TOTAL AUDIENCE _____

FIRES INVESTIGATED: (ACCIDENTAL) _____ (INCENDIARY) _____

Gerrit J. Alder

 FIRE MARSHAL, CITY OF LOS FRESNOS

Attachment: Fire marshal report (2851 : Fire Marshal's Report)